



547397 EN (06/10/2017)

80 VJR EVOLUTION
100 VJR EVOLUTION

OPERATOR'S MANUAL
(ORIGINAL INSTRUCTIONS)

IMPORTANT

Carefully read and understand this instruction manual before using the lifting platform.

*It contains all information relating to operation, handling and lifting platform equipment,
as well as important recommendations to be followed.*

*This document also contains precautions for use, as well as information on the servicing and routine maintenance required
to ensure the lifting platform's continued safety of use and reliability.*

WHenever you see this symbol it means:



WARNING ! BE CAREFUL ! YOUR SAFETY OR THE SAFETY OF THE LIFTING PLATFORM IS AT RISK.

- This manual has been produced on the basis of the equipment list and the technical characteristics given at the time of its design.
- The level of equipment of the lifting platform depends on the options chosen and the country of sale.
- According to the lifting platform options and the date of sale, certain items of equipment/functions described herein may not be available.
- Descriptions and figures are non binding.
- MANITOU reserves the right to change its models and their equipment without being required to update this manual.
- The MANITOU network, consisting exclusively of qualified professionals, is at your disposal to answer all your questions.
- This manual is an integral part of the lifting platform.
- It is to be kept in its storage space at all times for ease of reference.
- Hand this manual to the new owner if the lifting platform is resold.

1st ISSUE	27/01/2009	
UPDATED	31/08/2010	SECTION 3 ; SECTION 4 REMOVED ; 1-4 <-> 1-19 ; 2-4 ; 2-5 ; 2-8 ; 2-9 ; 3-5
	22/11/2010	2-33
	01/02/2015	UPDATE EN280
	01/03/2017	SECTION 1 ; SECTION 2 ; SECTION 3
	06/10/2017	1-22 <-> 1-24 ; 2-32 ; 3-20

Manitou BF S.A Limited liability company with a Board of Directors.

Head office: 430, Rue de l'Aubinière - 44150 Ancenis - FRANCE

Share capital: 39,548,949 euros

857 802 508 RCS Nantes.

Tel: +33 (0)2 40 09 10 11

www.manitou.com

This manual is for information purposes only. Any reproduction, copy, representation, recording, transfer, distribution, or other, in part or in whole, in any format is prohibited. The plans, designs, views, commentaries and instructions, even the document organization that are found in this document, are the intellectual property of MANITOU BF. Any violation of the aforementioned may lead to civil and criminal prosecution. The logos as well as the visual identity of the company are the property of MANITOU BF and may not be used without express and formal authorization. All rights are reserved.

1 - OPERATING AND SAFETY INSTRUCTIONS

2 - DESCRIPTION

3 - MAINTENANCE



1 - OPERATING AND SAFETY INSTRUCTIONS

TABLE OF CONTENTS

INSTRUCTIONS TO THE COMPANY MANAGER	1-4
FOREWORD	1-4
SITE	1-4
OPERATOR	1-4
PLATFORM	1-4
INSTRUCTIONS	1-5
MAINTENANCE	1-5
INSTRUCTIONS TO THE OPERATOR	1-6
FOREWORD	1-6
GENERAL INSTRUCTIONS	1-6
DRIVING INSTRUCTIONS	1-8
INSTRUCTIONS FOR WELDING AND BLOW TORCH WORK ON AN EXTERNAL STRUCTURE	1-15
PLATFORM MAINTENANCE INSTRUCTIONS	1-16
GENERAL INSTRUCTIONS	1-16
MAINTENANCE	1-16
LUBRICANT AND FUEL LEVELS	1-16
BATTERY ELECTROLYTE LEVEL	1-16
HYDRAULIC	1-17
ELECTRICITY	1-17
WELDING ON THE ACCESS PLATFORM	1-17
WASHING THE PLATFORM	1-17
IF THE PLATFORM IS NOT TO BE USED FOR A LONG TIME	1-18
INTRODUCTION	1-18
PREPARING THE PLATFORM	1-18
PROTECTING THE I.C. ENGINE	1-18
BATTERY CHARGE	1-19
PROTECTING THE PLATFORM	1-19
BRINGING THE PLATFORM BACK INTO SERVICE	1-19
DISPOSING OF THE PLATFORM	1-20
SAFETY DECALS	1-22

FOREWORD

WHENEVER YOU SEE THIS SYMBOL IT MEANS:



WARNING! BE CAREFUL! YOUR SAFETY OR THE SAFETY OF THE PLATFORM IS AT RISK.

SITE

- Proper management of the personnel lifting platform's area of travel will reduce the risk of accidents:
 - ground not unnecessarily uneven or obstructed,
 - no excessive slopes,
 - pedestrian traffic controlled, etc.

OPERATOR

- Only qualified, authorized personnel can use the platform. This authorization is given in writing by the appropriate person in the establishment where the platform is to be used and must be carried permanently by the operator.

Experience has shown that there are a number of inappropriate ways in which the platform might be used. Such foreseeable misuse, of which the main examples are listed below, are strictly forbidden.

- The foreseeable abnormal behavior resulting from ordinary negligence, but which does not result from any wish to put the machinery to any improper use.



- The reflex behavior of a person in the event of a malfunction, incident, failure, etc. during use of the platform.
- Behavior resulting from application of the "principle of least effort" when performing a task.
- For certain machines, the foreseeable behavior of such persons as: apprentices, teenagers, handicapped persons, trainees tempted to drive a platform, operators tempted to operate a truck to win a bet, in competition or for their own personal experience.
- The person in charge of the equipment must take these criteria into account when assessing the suitability of a person to drive.



OBTAIN INFORMATION ON:

- How to behave when there is a fire.
- The location of the nearest first aid kit and fire extinguisher.
- The emergency telephone numbers for calling (the doctors, ambulance, hospital and fire brigade).

PLATFORM

A - THE PLATFORM'S SUITABILITY FOR USE

- MANITOU has ensured that this platform is suitable for use under the standard operating conditions defined in this operator's manual, with an overload test coefficient of 1.25 and an operational test coefficient of 1.1, as stipulated in standardized norm EN 280 for MPLP (Mobile Personnel Lifting Platforms).

Before putting the platform into operation, the company manager must check that the platform is suitable for the work to be carried out and conduct certain tests (in accordance with current legislation).

B - ADAPTING THE PLATFORM TO THE USUAL ENVIRONMENTAL CONDITIONS

- In addition to series equipment mounted on your platform, many options are available, such as: rotating light, working light, etc. Contact your dealer.
- Take into account climatic and atmospheric conditions of the site of utilization.
 - Protection against frost (see: "3 - MAINTENANCE: LUBRICANTS").
 - Adaptation of lubricants (ask your dealer for information).
 - Engine filtration (see: "3 - MAINTENANCE: FILTER CARTRIDGES").

- The machines manufactured by MANITOU are designed to be used within the following temperature ranges:
 - Minimum temperature: -20°C
 - Maximum temperature: +45°C
- Special applications are available as options for particularly cold environments.



The factory fill of lubricants is for average climatic conditions, i.e. between -15°C and +35°C. For operation under more severe climatic conditions, before starting up, the systems should be drained and refilled using lubricants suited to the ambient temperatures.

- A platform operating in an area without fire extinguishing equipment must be equipped with an individual extinguisher. There are solutions, consult your dealer.



Your platform may be designed for outdoor use (see chapter 2 - DESCRIPTION, SPECIFICATIONS pages) under normal atmospheric conditions and indoor use in suitably aerated and ventilated premises. It is prohibited to use the platform in areas where there is a risk of fire or which are potentially explosive (e.g. refineries, fuel or gas depots, stores of flammable products, etc.). For use in these areas, specific equipment is available (ask your dealer for information).

C - MODIFYING THE PLATFORM

- For your own safety and that of others, you must not change the structure and settings of the various components used in your platform by yourself (hydraulic pressure, limiter calibration, engine speed, addition of extra equipment, addition of counterweights, unapproved attachments, alarm systems, etc.). In this event, the manufacturer cannot be held liable.
- Your platform is supplied with standard wheels or all-terrain wheels. It is PROHIBITED to change from one type of wheel to the other: risk of loss of stability of the platform.

INSTRUCTIONS

- The operator's manual must always be in good condition and kept in the place provided on the platform and in the language used by the operator.
- You must replace the instructions manual, as well as any plates or stickers, if they are no longer legible or are missing or damaged.

MAINTENANCE

- Maintenance or repairs other than those detailed in part: 3 - MAINTENANCE must be carried out by qualified personnel (consult your dealer) and under the necessary safety conditions to maintain the health of the operator and any third party.



Your platform must be inspected periodically to ensure that it remains in compliance. The frequency of this inspection is defined by the current legislation applying in the country in which the platform is used.

- Example for France: The manager in charge of the establishment using an access platform must open and maintain a maintenance log for each machine (order of 2 March 2004).

FOREWORD

WHENEVER YOU SEE THIS SYMBOL IT MEANS:



WARNING! BE CAREFUL! YOUR SAFETY OR THE SAFETY OF THE PLATFORM IS AT RISK.



The risk of accident while using, servicing or repairing your platform can be restricted if you follow the safety instructions and safety measures detailed in these instructions.

- Only the operations and maneuvers described in this operator's manual must be performed. The manufacturer cannot predict all possible risky situations. Consequently, the safety instructions given in the operator's manual and on the platform itself are not exhaustive.
- At all times as an operator you must envisage, within reason, the possible risk to yourself, to others or to the platform itself when you use it.



Failure to respect the safety and operating instructions, or the instructions for repairing or servicing your platform may lead to serious, even fatal accident.

GENERAL INSTRUCTIONS

A - OPERATOR'S MANUAL

- Carefully read and understand the operator's manual.
- The operator's manual must always be kept in the place provided for it on the platform and be written in the language used by the operator.
- Any operations or maneuvers not described in the operator's manual are categorically forbidden.
- Follow the safety advice and the instructions on the platform.
- You must necessarily replace the operator's manual, as well as any plates or stickers, if they are no longer legible or are damaged.
- A second operator must be present on the ground as a safety measure when using the platform.
- Familiarize yourself with the platform on the terrain where it will be used.
- The machine must also be used in accordance with good engineering practice.
- Do not use the platform if there is a wind speed of over 45 km/h. The platform's arms must not be subjected to a lateral force of more than 40 kg (platforms for indoor use must not be used outside the building).

B - AUTHORIZATION FOR USE IN FRANCE

(OR SEE CURRENT LEGISLATION IN OTHER COUNTRIES)

- Only qualified, authorized personnel can use the platform. This authorization is given in writing by the appropriate person in the establishment where the platform is to be used and must be carried permanently by the operator.
- The operator is not competent to authorize the driving of the platform by another person.

C - MAINTENANCE

- The operator must immediately advise his superior if his platform is not in good working order or does not comply with the safety notice.
- The operator is prohibited from carrying out any repairs or adjustments himself, unless he has been trained for this purpose. He must keep the platform properly cleaned if this is among his responsibilities.
- The operator must carry out daily maintenance (see 3 - MAINTENANCE: A - DAILY OR EVERY 5 HOURS' SERVICE).
- The operator must ensure that the tires are adapted to the nature of the ground (see area of the contact surface of the tires in "2 - DESCRIPTION: SPECIFICATIONS"). There are optional solutions; consult your dealer.



Do not use the platform if the tires are damaged or excessively worn, because this could put your own safety or that of others at risk, or cause damage to the platform itself.

In the case of electric platforms, the operator must ensure that:



- **The batteries are not replaced with lighter ones (compromising stability).**
- **Safety goggles are always worn when charging the batteries.**
- **The batteries are not charged in an explosive environment.**
- **There is no smoking and no naked flame directed towards the batteries when they are being handled;**
- **Removal / refit and fill levels control.**

D - MODIFYING THE PLATFORM

- For your safety and that of others, you must not change the structure and settings of the various components used in your platform yourself:
 - hydraulic pressure,
 - calibrating limiters,
 - I.C. engine speed,
 - addition of extra equipment,
 - addition of counterweight,
 - unapproved attachments,
 - alarm systems, etc.
- In this event, the manufacturer cannot be held responsible.



Your platform is supplied with standard wheels or all-terrain wheels. It is PROHIBITED to change from one type of wheel to the other: risk of loss of stability of the platform.

E - I.C. PLATFORM AXLES

- STANDARD AXLE:



The chassis is rigid, so the platform can be load bearing on only three wheels.

- OSCILLATING AXLE (IF THIS OPTION IS AVAILABLE):



The oscillating axle enables the platform, in the transport position, to have load-bearing on four wheels. When moving in the working position over uneven terrain, the oscillating axle is locked (the chassis is rigid) so the platform can be load bearing on only three wheels.

DRIVING INSTRUCTIONS

A - BEFORE STARTING THE PLATFORM

- Ensure that the intermediate rail is fully in the locked position before operating the platform from the basket.
- If the platform is new, see the section: Before starting the platform for the first time in chapter 1 - operating and safety instructions.
- Perform the daily service (see "3 - MAINTENANCE: A - DAILY OR EVERY 5 HOURS' SERVICE").
- Before starting the platform, check the levels:

- I.C. PLATFORMS:

- Engine oil
- Hydraulic tank oil
- Fuel
- Coolant

- ELECTRIC PLATFORMS:

- Hydraulic tank oil
- Battery charge level

- The platform must be in transport position (with the arms completely folded back or the scissors in the low position) before you enter it.
- Make sure the horn works.
- Check before operating the platform that the access gate has been properly locked.

B - DRIVER'S CAB OPERATING INSTRUCTIONS

- Whatever his experience, the operator is advised to familiarize himself with the position and operation of all the controls and instruments before operating the platform.
- Wear suitable clothing for driving the platform; do not wear baggy clothes.
- Make sure you have the appropriate protective equipment for the job to be done.
- Prolonged exposure to high noise levels may cause hearing problems. It is recommended to wear ear muffs to protect against excessive noise.
- Remain alert at all times when using the platform. Do not listen to the radio or music using headphones or earphones.
- For increased comfort, adopt the correct position at the platform's operator station.
- The operator must always be in the normal operator's position: it is prohibited to have arms or legs, or generally any part of the body, protruding from the basket.
- Safety helmets must be worn.
- MANITOU recommends a safety harness in the operator's size be provided when the platform is in use (for the harness attachment in the basket, see "2 - DESCRIPTION, INSTRUMENTS AND CONTROLS").
- The control units must never in any event be used for any other than their intended purposes (e.g. climbing onto or down from the platform, portmanteau, etc.).
- In the case of scissors-type platforms, it is forbidden to use the platform without the guardrails in place.
- Suspending a load under the basket or on any part of the lifting apparatus is strictly forbidden.
- The operator must not climb into or get down from the basket unless it is at ground level (with the lifting system folded).
- If the platform is equipped with steps, the basket must be positioned vertically with these before going up or down.
- The platform must not be fitted with attachments that increase the unit's wind load.
- Do not use a ladder or any improvised constructions in the basket to reach greater heights.
- Do not climb on the sides of the basket to reach greater heights.
- Never operate the platform when hands or feet are wet or soiled with greasy substances.

C - ENVIRONMENT

- Comply with site safety regulations.
- The platform can be maneuvered from the ground: ensure that you forbid access.
- If you have to use the platform in a dark area or at night, make sure it is equipped with working lights.
- The platforms may not be used as cranes or elevators for the permanent transport of people or materials, nor as jacks or supports.
- When operating, ensure that there is no one or anything impeding the platform's progress and operation.
- When raising the platform, ensure that no one or anything impedes the platform's operation and do not perform any inappropriate maneuvers.

- Do not allow anybody to come near the working area of the platform or pass beneath an elevated load. To ensure this, mark out your working area.
- Traveling on a longitudinal slope:
 - Ensure that you adapt the access platform's travel speed by controlling it with the travel manipulator.
- Take into account the platform's dimensions and its load before trying to negotiate a narrow or low passageway.
- Never move onto a loading platform without having first checked:
 - That it is suitably positioned and made fast.
 - That the unit to which it is connected (wagon, lorry, etc.) will not shift.
 - That this bridge is prescribed for the size and weight of the platform.
 - That the slope of the bridge is not greater than the platform's maximum authorized slope.
- Never move onto a foot bridge, floor or freight lift, without being certain that they are prescribed for the weight and size of the platform to be loaded and without having checked that they are in sound working order.
- Be careful in the area of loading bays, trenches, scaffolding, soft ground and manholes.
- Make sure the ground is stable and firm under the wheels and/or stabilizers before lifting the basket. If necessary, add sufficient wedging under the stabilizers.
- Do not attempt any operations outside the platform's capabilities.
- Ensure that any materials loaded onto the platform (pipes, cables, containers, etc.) cannot fall out. Do not pile these materials to the point where it is necessary to step over them.



If the basket must remain stationary over a structure for a long period, there is a risk that the basket will descend and rest on this structure because of the oil cooling in the cylinders or a minor leak in the cylinder locking system. To eliminate this risk:

- Regularly check the distance between the basket and the structure and re-adjust if necessary.
- If possible use the platform at an oil temperature as close as possible to ambient temperature.

- In the case of work near aerial lines, ensure that the safety distance is sufficient between the working area of the platform and the aerial line.



You must consult your local electrical agency. You could be electrocuted or seriously injured if you operate or park the platform too close to power cables.



If the platform is in contact with electric cables, press the emergency stop button. If you can, jump out of the basket without touching the basket and the ground at the same time.

Otherwise call for help, inform people not to touch the platform, or cut off or have someone else cut off the electricity supply to the cables.

- It is forbidden to use the platform close to electricity cables. Maintain the specified safe distances:

RATED VOLTAGE	DISTANCE ABOVE THE GROUND OR THE FLOOR IN METERS
50 < U < 1000	2,30 M
1000 < U < 30000	2,50 M
30000 < U < 45000	2,60 M
45000 < U < 63000	2,80 M
63000 < U < 90000	3,00 M
90000 < U < 150000	3,40 M
150000 < U < 225000	4,00 M
225000 < U < 400000	5,30 M
400000 < U < 750000	7,90 M



If the wind is in excess of 45 km/h, do not perform any movements liable to endanger the access platform's stability.

- To visually recognize this wind speed, refer to the empirical wind evaluation scale below:

BEAUFORT scale (wind speed at a height of 10 m on a flat site)						
Force	Type of wind	Speed (knots)	Speed (km/h)	Speed (m/s)	Effects on Land	Sea conditions
0	Calm	0 - 1	0 - 1	<0.3	Smoke rises vertically.	Sea is like a mirror.
1	Very light breeze	1 - 3	1 - 5	0,3 - 1,5	Smoke indicates direction of wind.	Ripples with appearance of scale, no foam crests.
2	Light breeze	4 - 6	6 - 11	1,6 - 3,3	Wind felt on face, leaves rustle.	Short wavelets, but pronounced.
3	Gentle breeze	7 - 10	12 - 19	3,4 - 5,4	Leaves and small twigs in constant motion.	Very small waves, crests begin to break.
4	Moderate breeze	11 - 16	20 - 28	5,5 - 7,9	Wind raises dust and loose pieces of paper; small branches are moved.	Small waves, becoming longer, numerous whitecaps.
5	Fresh breeze	17 - 21	29 - 38	8 - 10,7	Small trees in leaf begin to sway.	Wavelets form on inland waters; moderate waves, taking longer form.
6	Strong breeze	22 - 27	39 - 49	10,8 - 13,8	Large branches in motion, whistling heard in overhead wires, umbrella use becomes difficult.	Larger waves forming, whitecaps everywhere, some spray.
7	High wind	28 - 33	50 - 61	13,9 - 17,1	Whole trees in motion, inconvenience felt when walking against the wind.	Sea heaps up; white foam from breaking waves begins to be blown in streaks along the direction of the wind.
8	Gale	34 - 40	62 - 74	17,2 - 20,7	Wind breaks twigs off trees; impedes progress.	Moderately high waves of greater length; edges of crests begin to break into spin drift.
9	Strong gale	41 - 47	75 - 88	20,8 - 24,4	Wind damages roofs (chimneys, slates, etc.).	High waves, crests of waves begin to topple, streaks of foam; reduced visibility.
10	Storm	48 - 55	89 - 102	24,5 - 28,4	Seldom experienced inland; trees uprooted; considerable structural damage occurs.	Very high waves; white streaks of foam; reduced visibility.
11	Violent storm	56 - 63	103 - 117	28,5 - 32,6	Very rare, widespread damage.	Exceptionally high waves able to hide medium sized ships from view, reduced visibility.
12	Hurricane	64 +	118 +	32,7 +	Devastating damage.	Sea completely white; air filled with foam and spray, very reduced visibility.

D - VISIBILITY

- Ensure good visibility on your route at all times. To increase your visibility, you can move forwards with the jib arm slightly raised (beware of the risk of falls in the basket from knocking into a low doorway, overhead electric wires, traveling cranes, highway bridges, rail tracks or any obstacle in the area in front of the platform). In reverse, look directly behind you. At all events, avoid reversing long distances.
- If visibility of your road is inadequate, ask someone to help, standing outside the area in which the platform will be moving, and make sure you always have a good view of this person.

PLATFORMS WITH I.C. ENGINES

SAFETY INSTRUCTIONS

- Never try to start the platform by pushing or towing it. Such operation may cause severe damage to the transmission. If necessary, to tow the platform in an emergency, the transmission must be placed in the neutral position (see "3 - MAINTENANCE").
- If using an emergency battery for start-up, use a battery with the same characteristics and respect battery polarity when connecting it. Connect at first the positive terminals before the negative terminals.



Failure to respect polarity between batteries can cause serious damage to the electrical circuit. The electrolyte in the battery may produce an explosive gas. Avoid flames and generation of sparks close to the batteries. Never disconnect a battery while it is charging.

INSTRUCTIONS

- Check the closing and locking of the cover(s).
- Turn the ignition key to position I to switch on the electrical power, which automatically starts the preheating system (all the bars must be displayed), the message "OK" is displayed.
- Check that everything is operating correctly by ensuring that no fault pages are displayed on the screen and no warning about the fuel level (a pump icon remains present on the screen) (see "2 - DESCRIPTION: INSTRUMENTS AND CONTROLS").
- Turn the ignition key to position I to start.
- Press the start button.
- Do not engage the starter motor for more than 15 seconds and carry out the preheating for 10 seconds between unsuccessful attempts.
- Check the control screen when the engine is warm and at regular intervals during use, so as to quickly detect any faults and to be able to correct them without delay.
- If any faults are displayed on the screen, stop the engine and immediately take the necessary measures.

ELECTRIC PLATFORMS

SAFETY INSTRUCTIONS

- Do not use the platform if the battery is discharged to the point that movements are slowed down. In certain cases, the platform may stop (see "3 - MAINTENANCE: DAILY OR EVERY 5 HOURS' SERVICE" for the charge level not to be exceeded).

INSTRUCTIONS

- Set the battery cut-off to the ON position.
- Check the closing and locking of the cover(s).
- Turn the ignition key to the basket position.
- Check that everything is operating correctly by ensuring that no error messages are displayed on the screen and that the machine maintenance light is not flashing (see "2 - DESCRIPTION, INSTRUMENTS AND CONTROLS").

NOTE: For machines not fitted with a display or a maintenance warning light, faults can be identified from the light directly on the variable speed drive unit (to access: open the cowl on the control side, remove the casing from the variable speed drive and see whether the light is flashing).

- If any error messages are constantly displayed or the machine maintenance light is flashing, return the key to the neutral position.
- Set the battery cut-off to the OFF position.
- Immediately take the necessary measures.

SAFETY INSTRUCTIONS



Operators should be aware of the risks connected with using the platform, notably:

- Risk of losing control.
- Risk of losing lateral and frontal stability of the platform.

The operator must remain in control of the platform.

- Do not carry out operations which exceed the capacities of your platform.
- Familiarize yourself with the platform on the terrain where it will be used.
- Ensure that the brakes work efficiently when stopping a traveling movement, taking into account the braking distances.
- Drive smoothly at an appropriate speed for the operating conditions (site configuration, load in the basket).
- Take extreme care when maneuvering the platform with the basket in the high position. Ensure that there is sufficient visibility.
- Take bends slowly.
- In all circumstances make sure you are in control of your speed.
- Travel slowly on damp, slippery or uneven terrain or on truck ramps.
- Always remember that the hydraulic steering is very sensitive to movements.
- Never leave the I.C. engine on when the platform is unattended.
- Look where you are going and always make sure you have good visibility along the route.
- Drive round obstacles.
- Never drive on the edge of a ditch or steep slope.
- Whatever your traveling speed, you must reduce the speed as much as possible before stopping.
- The platform should be operated in an area free of any obstructions or danger when it is lowered to the ground.
- The operator using the platform must be aided on the ground by a person with adequate training.
- You should stay within the limits set out in the platform load chart.

INSTRUCTIONS

- When moving the platform a long distance, always travel with the arms folded or the scissors in the low position.
- Engage the appropriate gear (see "2 - DESCRIPTION: INSTRUMENTS AND CONTROLS).

G - STOPPING THE PLATFORM

SAFETY INSTRUCTIONS

- Never leave the ignition key in the platform during the operator's absence.
- Make sure that the platform is not stopped in any position that will interfere with the traffic flow and in particular the platform should not be at less than one meter from a railroad track.
- In the event of prolonged parking on a site, protect the platform from bad weather, particularly from frost (check the level of antifreeze), and close and lock all the platform accesses (cowls, etc.).
- Park the platform on flat ground or on an incline lower than 10%.

INSTRUCTIONS

PLATFORMS WITH I.C. ENGINES

- Before stopping the platform after a long working period, leave the I.C. engine idling for a few moments, to allow the coolant and oil to lower the temperature of the I.C. engine and transmission.



Do not forget this precaution, in the event of frequent stops or warm stalling of the I.C. engine, or else the temperature of certain parts will rise significantly due to the stopping of the cooling system, with the risk of badly damaging such parts.

- Stop the engine with the ignition switch.
- Remove the ignition key.
- Check that all the accesses on the platform are closed and locked (cowls, etc.).

ELECTRIC PLATFORMS

- Remove the ground/platform control selection key.
- Check that all the accesses on the platform are closed and locked (cowls, etc.).
- Set the battery cut-off to the OFF position.

INSTRUCTIONS FOR WELDING AND BLOW TORCH WORK ON AN EXTERNAL STRUCTURE



Ensure that there are no hydraulic or electrolyte leaks on the platform.



When welding, work in the opposite direction from the control console to avoid sparks damaging it.

- Any welding and cutting (blow torch) work from the basket on a building's metallic structures requires the following precautions to be taken:

A - WITH AN ELECTRICAL WELDING SET

- It is essential that the machine has a discharge braid connecting the frame of the platform to the ground.
- The external structure to be welded must, without fail, be grounded. If the above conditions are observed, the platform can, in this case, be in contact with the structure or the elements to be welded without damaging the electronic components.
- The power supply to the welding equipment must be via a grounded socket, including the extension lead if required.
- In all cases, make sure that there are no electric arcs in the basket or on the platform (contact between the rod or torch and ground connector of the welding equipment). For this the ground connector of the welding must never be placed on the platform's basket; it must only be placed as close as possible to the part to be welded.
- Switch off the welding equipment before disconnecting the ground clamp from the element or elements to be welded.

B - WITH A BLOW TORCH

- Attach the blow torch's bottles to the basket's handrails.
- Sparks and clippings must not be directed towards the batteries.
- Do not set the blow torch down on the lip of the basket while it is still operating or point it towards the control console or its power cables.

PLATFORM MAINTENANCE INSTRUCTIONS

GENERAL INSTRUCTIONS

- Make sure the area is adequately ventilated before starting up the platform.
- Wear clothes suitable for the maintenance of the lift truck, avoid wearing jewelry and loose clothes. Tie and protect your hair, if necessary.
- Stop the I.C. engine before conducting any work on the platform, remove the ignition key and disconnect the "Minus" battery terminal.
- Set the battery cut-off to the OFF position (ELECTRIC PLATFORM).
- Read the operator's manual carefully.
- Carry out all repairs immediately, even if the repairs concerned are minor.
- Repair all leaks immediately, even if the leak concerned is minor.
- Ensure that consumables and used parts are disposed of in a safe and ecological manner.
- Be careful of the risk of burning and splashing (exhaust, radiator, engine, etc.).

MAINTENANCE

- Perform the periodic service (see "3 - MAINTENANCE") to keep your platform in good working condition. Failure to perform the periodic service may annul the contractual guarantee.

MAINTENANCE LOGBOOK

- The maintenance operations carried out in accordance with the recommendations given in part "3 - MAINTENANCE" and the other inspection, servicing or repair operations or modifications performed on platform shall be recorded in a maintenance logbook. The entry for each operation shall include details of the date of the works, the names of the individuals or companies having performed them, the type of operation and its frequency, if applicable. The part numbers of any platform items replaced shall also be indicated.

LUBRICANT AND FUEL LEVELS

- Use the recommended lubricants (never use contaminated lubricants).
- Do not fill the fuel tank when the engine is running.
- Only fill up the fuel tank in areas specified for this purpose.
- Do not fill the fuel tank to the maximum level.
- Do not smoke or approach the platform with a flame, when the fuel tank is open or is being filled.

BATTERY ELECTROLYTE LEVEL

- Check the level of the battery or batteries.



When doing this, ensure you take all the safety precautions (see "3 - MAINTENANCE").

HYDRAULIC

- Make any repairs and fix any leaks, including minor ones, immediately.
- Do not attempt to loosen unions, hoses or any hydraulic component when the circuit is under pressure.



BALANCING VALVE: It is dangerous to change the setting or remove the balancing valves or safety valves which may be fitted to your platform cylinders. These operations must only be performed by approved personnel (consult your dealer).



Ensure that all consumables and replacement parts are disposed of safely, in an environmentally friendly manner.



The HYDRAULIC ACCUMULATORS that may be fitted on your platform are pressurized units. Removing these accumulators and their pipework is a dangerous operation and must only be performed by approved personnel (consult your dealer).

ELECTRICITY

- Do not put metal items on the battery (between the "Plus" and "Minus" terminals).
- Disconnect the battery or batteries before working on the electrical circuit.
- The electrical box must only be opened by authorized personnel.

WELDING ON THE ACCESS PLATFORM

- Disconnect the battery or batteries before welding on the platform.
- When carrying out electric welding work on the platform, connect the negative cable from the welding equipment directly to the part being welded, so as to avoid high tension current passing through the alternator or the slewing ring.
- If the platform is equipped with an electronic control unit, disconnect this before starting to weld, to avoid the risk of causing irreparable damage to electronic components.



Welding operations for the purposes of maintenance or repairs must only be carried out by persons authorized by MANITOU.

WASHING THE PLATFORM

- Clean the platform or at least the area concerned before any intervention.
- Remember to close and lock all accesses to the platform (cowls, etc.).
- When cleaning with a pressure washer, avoid the articulation joints, and the electrical components and connections.
- If necessary, protect components likely to be damaged, and in particular the electrical components (variable speed drive, charger) and connections and the injection pump from penetration by water, steam or cleaning products.
- Dry the electrical components.
- Clean the platform of any fuel, oil or grease trace.
- Grease the shafts.

FOR ANY OPERATIONS OTHER THAN REGULAR MAINTENANCE OPERATIONS, CONSULT YOUR DEALER

IF THE PLATFORM IS NOT TO BE USED FOR A LONG TIME

INTRODUCTION

The following recommendations are intended to prevent the platform from being damaged when it is withdrawn from service for an extended period.

For these operations, we recommend the use of a MANITOU protective product, reference 603726.

Instructions for using the product are given on the packaging.



Procedures to follow if the platform is not to be used for a long time and for starting it up again afterwards must be performed by your dealership.

PREPARING THE PLATFORM

- Clean the platform thoroughly.
- Check and repair any leakage of fuel, oil, water or air.
- Replace or repair any worn or damaged parts.
- Wash the painted surfaces of the platform in clear and cold water and wipe them.
- Touch up the paintwork if necessary.
- Shut down the platform (see "OPERATING INSTRUCTIONS UNLADEN AND LADEN").
- Make sure the cylinder rods are all in the retracted position.
- Release the pressure in the hydraulic circuits.

PROTECTING THE I.C. ENGINE

- Fill the tank with fuel (see "3 - MAINTENANCE").
- Empty and replace the coolant (see "3 - MAINTENANCE").
- Leave the I.C. engine running at idling speed for a few minutes, then switch off.
- Replace the I.C. engine oil and oil filter (see "3 - MAINTENANCE").
- Add the protective product for engine oil.
- Run the I.C. engine for a short time so that the oil and coolant circulate inside.
- Disconnect the battery and store it in a safe place away from the cold, after charging it to a maximum.
- Remove the injectors and spray the protective product into each cylinder for one to two seconds with the piston at bottom dead center.
- Turn the crankshaft once slowly and refit the injectors (see I.C. engine REPAIR MANUAL).
- Remove the intake hose from the manifold or turbocharger and spray the protective product into the manifold or turbocharger.
- Cap the intake manifold port with waterproof adhesive tape.
- Remove the exhaust pipe and spray the protective product into the exhaust manifold.
- Refit the exhaust pipe and block the outlet of the muffler with waterproof adhesive tape.

NOTE: The spray time is noted on the product packaging.

- Open the filler plug, spray the protective product around the rocker shaft and refit the filler plug.
- Cap the fuel tank using waterproof adhesive tape.
- Remove the drive belts and store them in a safe place.
- Disconnect the engine cut-off solenoid on the injection pump and carefully insulate the connection.

BATTERY CHARGE

- In the case of electric platforms, in order to preserve the batteries' life and their capacity, check them periodically and keep the charge level constant (see "3 - MAINTENANCE").

PROTECTING THE PLATFORM

- Protect cylinder rods which are not be retracted from corrosion.
 - Wrap the tires.
- NOTE: If the platform is to be stored outdoors, cover it with a waterproof tarpaulin.

BRINGING THE PLATFORM BACK INTO SERVICE

- Remove the waterproof adhesive tape from all the orifices.
- Refit the intake hose.
- Reconnect the engine cut-off solenoid.
- Refit and reconnect the battery.
- Remove the protection from the cylinder rods.
- Perform the daily service (see "3 - MAINTENANCE").
- Empty and replace the fuel and replace the fuel filter (see "3 - MAINTENANCE").
- Refit the drive belts and adjust the tension (see "3 - MAINTENANCE").
- Turn the engine over with the starter, to allow the oil pressure to rise.
- Lubricate the platform completely (see "3 - MAINTENANCE: SERVICING SCHEDULE").



Make sure the area is adequately ventilated before starting up the platform.

- Start up the platform, following the safety instructions and regulations (see "DRIVING INSTRUCTIONS").
- Carry out all the lifting system's hydraulic movements right up to the limit switches for each cylinder.

DISPOSING OF THE PLATFORM



Consult your dealer before disposing of your platform.

RECYCLING OF MATERIALS

METALS

- Metals are 100 % recoverable and recyclable.

PLASTICS

- Plastic parts are identified with a marking in accordance with current regulations.
- A limited range of materials is used to simplify the recycling process.
- The majority of plastic components are made of "thermoplastic" plastics, that are easily recycled by melting, granulating or grinding.

RUBBER

- Tires and seals can be ground for use in cement manufacture or to obtain reusable granules.

GLASS

- Glass items can be removed and collected for processing by glaziers.

ENVIRONMENTAL PROTECTION

By entrusting the maintenance of your platform to the MANITOU network, the risk of pollution is limited and the contribution to environmental protection is made.

WORN OR DAMAGED PARTS

- Do not dump them in the countryside.
- MANITOU and its network have signed-up to a scheme of environmental protection through recycling.

USED OIL

- The MANITOU network organizes the collection and processing of used oil products.
- By handing over your waste oil to MANITOU, the risk of pollution is limited.

USED BATTERIES

- Do not throw away batteries, as they contain metals that are harmful for the environment.
- Return them to the MANITOU network or any other approved collection point.

NOTE: MANITOU aims to manufacture platforms that provide the best performance and limit polluting emissions.

SAFETY DECALS

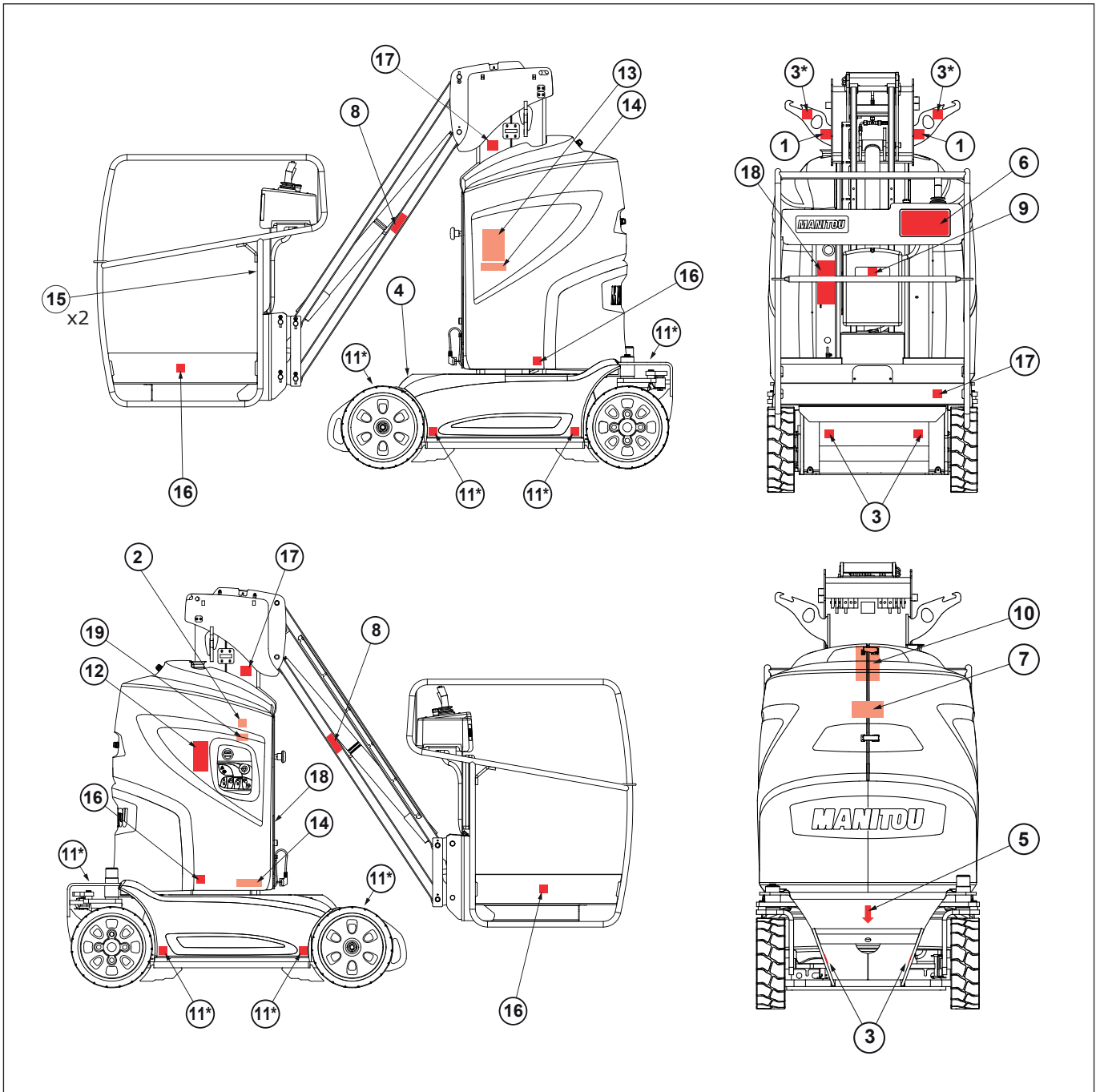

(1) - (2): According to model

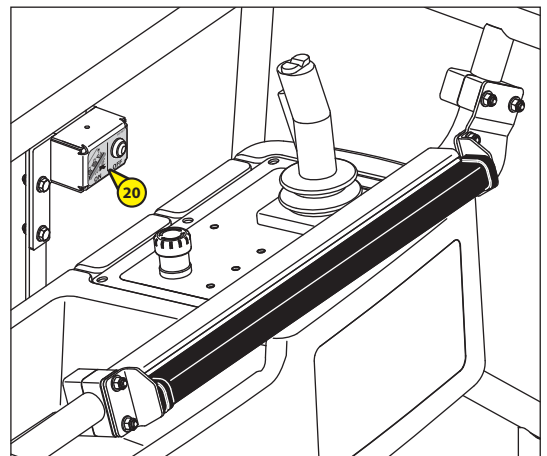

547397 (06/10/2017)
80/100 VIREVOLUTION

1 - SLINGING POINT	PART NO.: 830 203
2 - WARNING DANGER	PART NO.: 830 871
3 - TIE-DOWN POINT	PART NO.: 598 895
4 - BLACK ARROW	PART NO.: 498 326
5 - WHITE ARROW	PART NO.: 498 327
6 - BASKET INSTRUCTIONS	PART NO.: 830 096
7 - MANUAL PUMP LEVER LOCATION	PART NO.: 830 286
8 - SAFETY VALVE	PART NO.: 830 123
9 - LOCATION OF ACCESS PLATFORM KEY	PART NO.: 598 897
10 - BATTERY REPLACEMENT	PART NO.: 677 856
11 - LOAD ON WHEELS	PART NO.: 830 884
12 - SAFETY, WASHING, LOADING AND UNLOADING INSTRUCTIONS	PART NO.: 830 102
13 - MANUAL CONTROL PROCEDURE	PART NO.: 830 099
14 - TELESCOPIC MAST MANUAL CONTROL PROCEDURE	PART NO.: 830 100
15 - SAFETY HOOK-UP	PART NO.: 834 438
16 - DANGER, RISK OF CRUSHING	PART NO.: 679 452
17 - DANGER, KEEP AWAY	PART NO.: 679 450
18 - BATTERY SAFETY	PART NO.: 830 119
19 - FREEWHEELING	PART NO.: 525 23 260
20 - RESET BUTTON LOCATION (SAFEMAN SYSTEM OPTION)	PART NO.: 525 13 971

MEANING

1 - SLINGING POINT

This sticker indicates the location of the slinging points for lifting the access platform with a crane.



2 - WARNING DANGER

This sticker warns of danger close by.



3 - TIE-DOWN POINT

This sticker indicates the platform tie-down points on a flatbed.



4 - BLACK ARROW

This indicates the direction of travel when reversing.

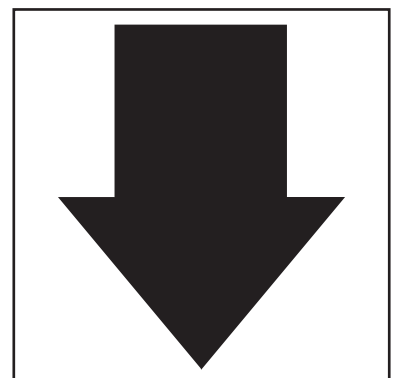

When the turn table, structure, arm and basket assembly rotates by 180° with respect to the frame, the travel controls are reversed. Identify the direction of movement by looking at the arrows on the frame and those on the basket control panel.

5 - WHITE ARROW

This indicates the direction of travel when moving forward.



When the turret, structure, arm and basket assembly rotates by 180° in relation to the chassis, the translation controls are reversed. Identify the direction of movement by looking at the arrows on the chassis and those on the basket control console.

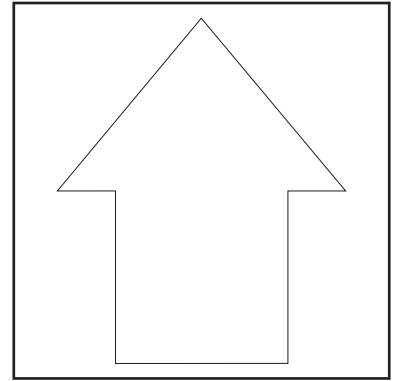

6 - BASKET INSTRUCTIONS AND LOAD CAPACITY

This describes several points:

- The platform's capacity for indoor and outdoor use.
- The risk of electric shock.
- An invitation to read the manual for more detailed information on the safety instructions.
- It is strictly forbidden to direct a pressure washer's nozzle over the control buttons and electrical components.

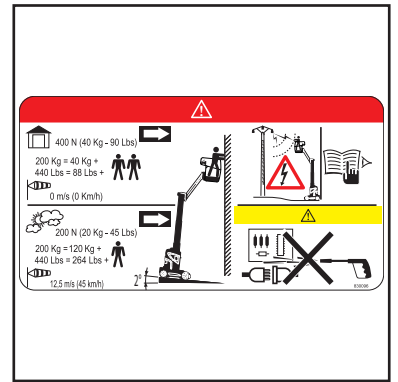

7 - MANUAL PUMP LEVER LOCATION

This sticker shows the location of the emergency manual pump lever.

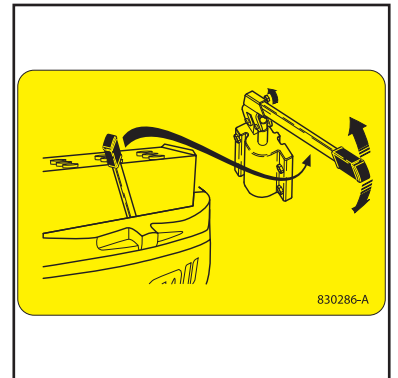

8 - SAFETY VALVE

This sticker shows the location of the safety valve on the jib.



9 - LOCATION OF ACCESS PLATFORM KEY

The platform's spare keys are stored in this place.

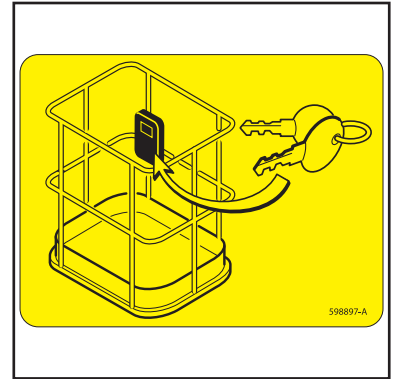

10 - BATTERY REPLACEMENT

Indicates that the weight of the new battery must be the same or greater than that of the battery you are replacing. If this rule is not respected, the stability of the platform will be compromised.

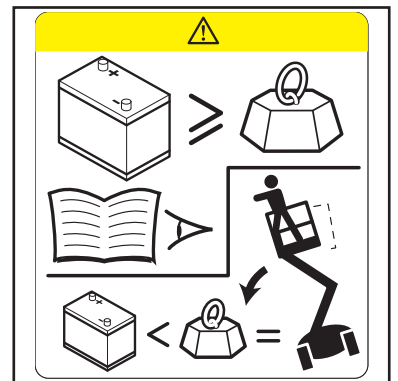

11 - LOAD ON WHEELS

This indicates the maximum load on one wheel and the load that the wheel will exert on the ground (see "2 - DESCRIPTION: SPECIFICATIONS" to find out the ground bearing pressure).

NOTE: Each access platform has its own specific capacity. Please refer to this sticker for your particular access platform.

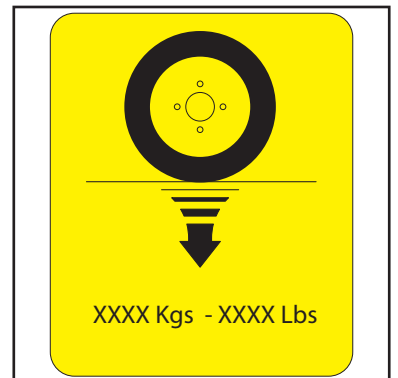

12 - SAFETY, WASHING, LOADING AND UNLOADING INSTRUCTIONS

This sticker states that the safety and operating instructions must be read before starting the platform, that it is strictly prohibited to direct a high-pressure jet onto the control buttons and electrical components, and that the direction of descent or ascent on vehicle loading ramps must be respected.



13 - MANUAL CONTROL PROCEDURE

This describes the procedure for turning the turret, turning the wheels and lowering the jib with the emergency pump and the manual controls, if an accident or breakdown occurs.

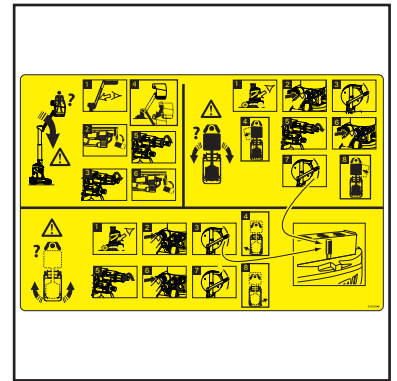

14 - TELESCOPIC MAST MANUAL CONTROL PROCEDURE

Describes the procedure for lowering the telescopic mast with a manual control, if an accident or breakdown occurs.

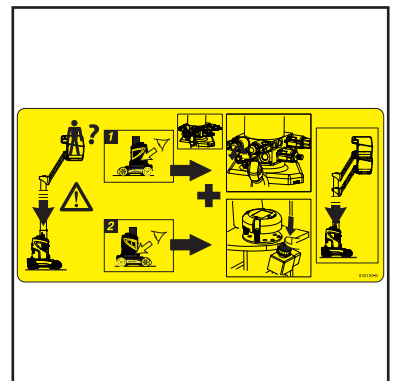

15 - SAFETY HOOK-UP

This stick indicates the place where the safety harness must be attached and the number of people per attachment point.



16 - DANGER, RISK OF CRUSHING

It is strictly prohibited to stand in this area when the platform is moving (rotation, etc.). The components where the stickers are affixed could collide with you: risk of crushing.



17 - DANGER, KEEP AWAY

It is strictly forbidden to walk under or stand under the structure (jib, basket, etc.) and in the access platform's operating area.



18 - BATTERY SAFETY

A - BATTERY CUT-OFF

This indicates the position of the battery cut-off and its effect:
 OFF Position: no current flows.
 ON Position: current flows.

B - BATTERY CHARGING DANGER

This describes three points:

- The risk of explosion when the batteries are being charged.
- The battery must be charged out-of-doors or in a well-ventilated area.
- The risk of explosion during charging due to a spark, naked flame or short-circuit.



Do not smoke near to the access platform while the batteries are being charged.

C - SOCKET: 230 VOLTS 16A

This informs you that, in order to charge the batteries, you must connect the charger to a socket supplying a voltage of 230 Volts with a current of 16 Amps.



The socket must be protected by a differential circuit breaker providing 30 mA protection.



19 - FREEWHEELING

This sticker signifies that the machine can be put in freewheeling mode (depending on the model).

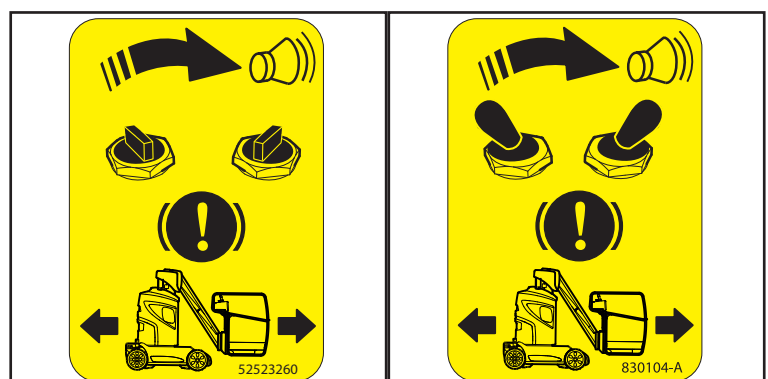

20 - RESET BUTTON LOCATION (SafeManSystem OPTION)

This sticker indicates the location of the reset button of the SafeManSystem option. See the "DESCRIPTION AND USE OF THE OPTIONS" chapter.

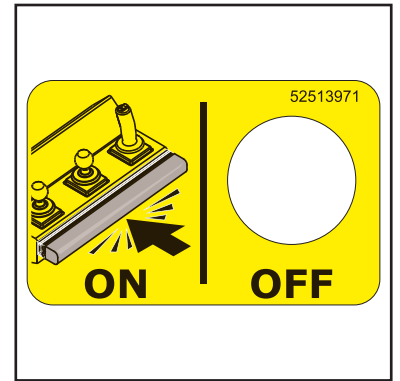

2 - DESCRIPTION

TABLE OF CONTENTS

<i>“CE” DECLARATION OF CONFORMITY</i>	<i>2-4</i>
<i>IDENTIFICATION OF THE ACCESS PLATFORM</i>	<i>2-8</i>
<i>SPECIFICATIONS</i>	<i>2-9</i>
<i>80 VJR WORKING DIMENSIONS</i>	<i>2-12</i>
<i>100 VJR WORKING DIMENSIONS</i>	<i>2-14</i>
<i>PLATFORM OPERATION</i>	<i>2-16</i>
<i>INSTRUMENTS AND CONTROLS</i>	<i>2-18</i>
<i>GROUND EMERGENCY AND MAINTENANCE CONSOLE</i>	<i>2-22</i>
<i>BASKET CONTROL CONSOLE</i>	<i>2-26</i>
<i>USING THE PLATFORM</i>	<i>2-30</i>
<i>RESCUE PROCEDURE</i>	<i>2-33</i>
<i>FREEWHEELING PROCEDURE</i>	<i>2-35</i>
<i>ACTIVATION OF OPTIONS</i>	<i>2-36</i>
<i>DESCRIPTION AND USE OF THE OPTIONS</i>	<i>2-37</i>

DECLARATION "CE" DE CONFORMITE (originale) "EC" DECLARATION OF CONFORMITY (original) (1)

(2) Constructeur, **manufacturer** : Manitou BF
 (3) Adresse, **Address** : 430, RUE DE L'AUBINIÈRE - B.P 10249
 44158 - ANCENIS - CEDEX - FRANCE

(4) Titulaire du dossier technique, **Holder of the technical file** : Manitou BF
 (3) Adresse, **Address** : 430, RUE DE L'AUBINIÈRE - B.P 10249
 44158 - ANCENIS - CEDEX - FRANCE

(5) Le constructeur déclare que la machine décrite ci-après, **The manufacturer declares that the machine described below** : **80 VJR EVOLUTION - 100 VJR EVOLUTION**

(6) - Est conforme aux directives suivantes et à leurs transpositions en droit national (si applicables), **Complies with the following directives and their transpositions into national law (if applicable)** :

2006/42/CE

(7) - Pour les machines annexe IV, **For annex IV machines** :

(8) - Numéro d'attestation, **Certificate number** : 0526 5131 xxx xx xx xxxx

(9) - Organisme notifié, **Notified body** : CETIM - 52 AVENUE FELIX LOUAT
 BP 80067 - 60304 SENLIS CEDEX

2000/14/CE + 2005/88/CE

(10) - Procédure appliquée, **Applied procedure** :

(9) - Organisme notifié, **Notified body** : SNCH - 11 ROUTE DU LUXEMBOURG
 5201 SANDWEILER

(11) - Niveau de puissance acoustique, **Sound power level** :

(12) Mesuré, **Measured** : dB (A)

(13) Garanti, **Guaranteed** : dB (A)

2004/108/CE jusqu'au 19/04/2016 et 2014/30/UE à partir du 20/04/2016

(14) - Normes harmonisées utilisées, **Harmonised standards used** :
 EN12895

(15) - Normes ou dispositions techniques utilisées, **Standards or technical provisions used** :

(16) - Fait à, **Done at** :

(17) - Date, **Date** :

(18) - Nom du signataire, **Name of signatory** :

(19) - Fonction, **Function** :

(20) - Société, **Company** :

(21) - Signature, **Signature** :

DECLARATION "CE" DE CONFORMITE (originale) **"EC" DECLARATION OF CONFORMITY (original)** (1)

- (2) Constructeur, **manufacturer** : Manitou BF
(3) Adresse, **Address** : 430, RUE DE L'AUBINIÈRE - B.P 10249
44158 - ANCENIS - CEDEX - FRANCE
(4) Titulaire du dossier technique, **Holder of the technical file** : Manitou BF
(3) Adresse, **Address** : 430, RUE DE L'AUBINIÈRE - B.P 10249
44158 - ANCENIS - CEDEX - FRANCE
(5) Le constructeur déclare que la machine décrite ci-après, **The manufacturer declares that the machine described below** : **80 VJR EVOLUTION - 100 VJR EVOLUTION**

- (6) - Est conforme aux directives suivantes et à leurs transpositions en droit national (si applicables), **Complies with the following directives and their transpositions into national law (if applicable)** :

2006/42/CE

- (7) - Pour les machines annexe IV, **For annex IV machines** :

(8) - Numéro d'attestation, **Certificate number** : 0062 5131 xxx xx xx xxxx

(9) - Organisme notifié, **Notified body** : BUREAU VERITAS INT. - 61-71 BD DU CHATEAU
92200 NEUILLY-SUR-SEINE

2000/14/CE + 2005/88/CE

- (10) - Procédure appliquée, **Applied procedure** :

(9) - Organisme notifié, **Notified body** : SNCH - 11 ROUTE DU LUXEMBOURG
5201 SANDWEILER

- (11) - Niveau de puissance acoustique, **Sound power level** :

(12) Mesuré, **Measured** : dB (A)

(13) Garanti, **Guaranteed** : dB (A)

2004/108/CE jusqu'au 19/04/2016 et 2014/30/UE à partir du 20/04/2016

- (14) - Normes harmonisées utilisées, **Harmonised standards used** :
EN12895

- (15) - Normes ou dispositions techniques utilisées, **Standards or technical provisions used** :

(16) - Fait à, **Done at** :

(17) - Date, **Date** :

(18) - Nom du signataire, **Name of signatory** :

(19) - Fonction, **Function** :

(20) - Société, **Company** :

(21) - Signature, **Signature** :

IDENTIFICATION OF THE ACCESS PLATFORM

In view of our policy of constantly improving our products, we may make certain modifications to our access platform range without notifying our customers in advance.

When you order parts, or when you require any technical information, always specify:

NOTE: We recommend that you write these numbers down in the places provided for this purpose when you receive the access platform so that you can pass them on more easily when required.

ACCESS PLATFORM MANUFACTURER'S PLATE (FIG. A)

- Type:
- Serial no.:
- Year of manufacture:

		INTERIEUR INSIDE	EXTERIEUR OUTSIDE
MANITOU BF 44158 ANCENIS CEDEX FRANCE		Charge maxi Max. load	kg
MODELE MODEL		Nb personnes maxi Max. no of persons	
N° dans la série Serial no.		Equipement Attachment	
Année de fabrication Year of manufacture		Forces manuelles Manual forces	kg
Masse à vide Empty weight	kg	Inclinaison maxi Max. tilt	daN
Puissance Power	kW	Vitesse maxi du vent Max. wind speed	m/s
Tension Voltage	VDC	Source électrique ext Ext. electrical source	Volts
		N° 830122	

LOCATION OF THE MANUFACTURER'S PLATE (FIG. B)

The manufacturer's plate is fastened on the telescopic mast pillar.

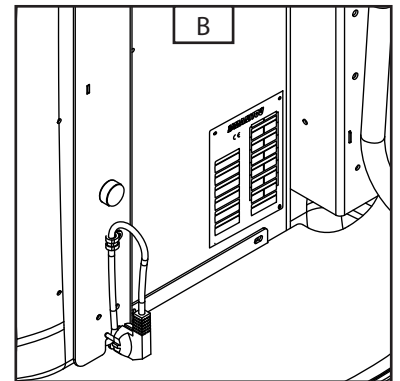

SPECIFICATIONS

CARD FUSES

- Board (box for emergency and ground control station)
- Power (box for emergency and ground control station)
- Brake release

F1 5A and F2 6.3A (Fig. A)
250 A (Fig. B)
5 A (Fig. C)

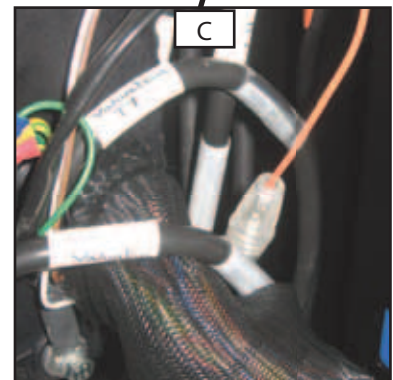
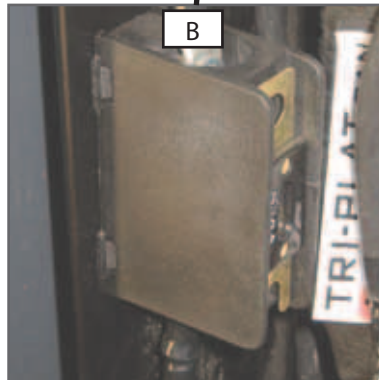
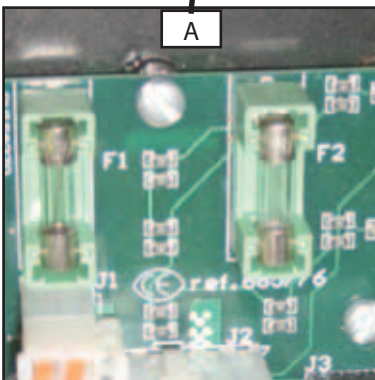

SPECIFICATIONS

LOAD SPECIFICATIONS		100 VJRE	80 VJRE	TOL ±
Platform				
Capacity for indoor use (Wind 0 Km/h)	kg	200	200	-
Capacity for outdoor use (Wind 45 Km/h)	kg	200	200	-
Number of people in the basket in indoor use		2	2	-
Number of people in the basket in outdoor use		1	1	-
Unladen platform ground	kg	2650	2250	20
Authorized maximum tilt	° - %	2 - 3.5	2 - 3.5	0,1
Gradeability (80 Kg)	%	25	25	2
Gradeability (200 Kg)	%	25	25	2
Working speed	Km/h	0,65	0,65	0,1
Transport speed (1)	Km/h	4,5	4,5	0,2
Transport speed (2)	Km/h	-	-	0,2
Transport speed (3)	Km/h	-	-	0,2
Wheels				
Front wheel loaded radius (Transport)	mm	197	197	2
Rear wheel loaded radius (Transport)	mm	200	199	2
Load on front wheel (transport position)	kg	830	680	5
Load on rear wheel (transport position)	kg	570	480	5
Maximum wheel load	kg	1490	1272	5
Bearing surface on ground (hard / soft)	cm ²	126.4 / 161.2	114 / 150	3
Ground bearing pressure (hard / loose)	daN/cm ²	11.8 / 9.2	11.1 / 8.5	-
Noise level LwA	dB	-	-	-

HYDRAULIC MOVEMENT (basket control signal)		100 VJRE	80 VJRE	TOL ±
Arm movement 1/2				
Unladen / laden lifting	s	-	-	5
Unladen / laden lowering	s	-	-	5
Arm movement 3 (telescope extended)				
Unladen / laden lifting	s	-	-	5
Unladen / laden lowering	s	-	-	5
Arm movement 3 (telescope retracted)				
Unladen / laden lifting	s	-	-	5
Unladen / laden lowering	s	-	-	5
Telescope movement				
Extended unladen / laden	s	52 / 54	23 / 24	5
Retracted unladen / laden	s	42 / 40	26 / 19	5
Jib movement				
Unladen / laden lifting	s	12 / 25	12 / 21	5
Unladen / laden lowering	s	21 / 17	21 / 19	5
Turret rotational movement (Telescope extended)				
Rotation through 350° (Telescope Extended / Retracted)	s	37	37	5
Basket rotation movement				
180° rotation	s	-	-	5

HYDRAULIC CIRCUIT		100 VJRE	80 VJRE	TOL ±
(Main) hydraulic pump				
Type		Mini unit - HYDAC		-
Cubic capacity	cm3	4,2	4,2	-
Flow rate at nominal unladen rpm	l/min.	-	-	-
Flow rate at max. unladen rpm	l/min.	18	18	-
Maximum service pressure	bar	140	140	5
(Auxiliary) hydraulic pump				
Type		-		-
Cubic capacity	cm3	-	-	-
Flow rate at nominal unladen rpm	l/min.	-	-	-
Flow rate at max. unladen rpm	l/min.	-	-	-
Maximum service pressure	bar	-	-	5
Filtration				
Return	µm	-	-	-
Suction	µm	100 (β10)	100 (β10)	-
Pressure	µm	-	-	-

ELECTRIC CIRCUIT		100 VJRE	80 VJRE	TOL ±
Battery				
Supplier (Original equipment)		HAWKER		-
Capacity C5	Ah	250	250	-
Capacity C20	Ah	270	270	-
Rated voltage	V	24	24	-
Type		Traction		-
EARL cycle		29	29	-
Charger				
Supplier (Original equipment)		IES		-
Maximum current	Ah	30	30	-
Rated voltage	V	24	24	-
Electric pump				
Power	kW	2,2	2,2	-
Supply voltage	V/DC	24	24	-
Current	A	190	190	-
S2 (temporary operation)	min.	6	6	-
S3 (alternate operation)	%	15	15	-
Alternator				
Type		-	-	-
current	A	-	-	-
Voltage	V	-	-	-
Starter				
Type		-	-	-
Power	kW	-	-	-
Voltage	V	-	-	-

VIBRATION LEVEL	UNIT	100 VJRE	80 VJRE	TOL ±
Average quadratic values for the body	m/s ²	<0.5		-

80 VJR WORKING DIMENSIONS

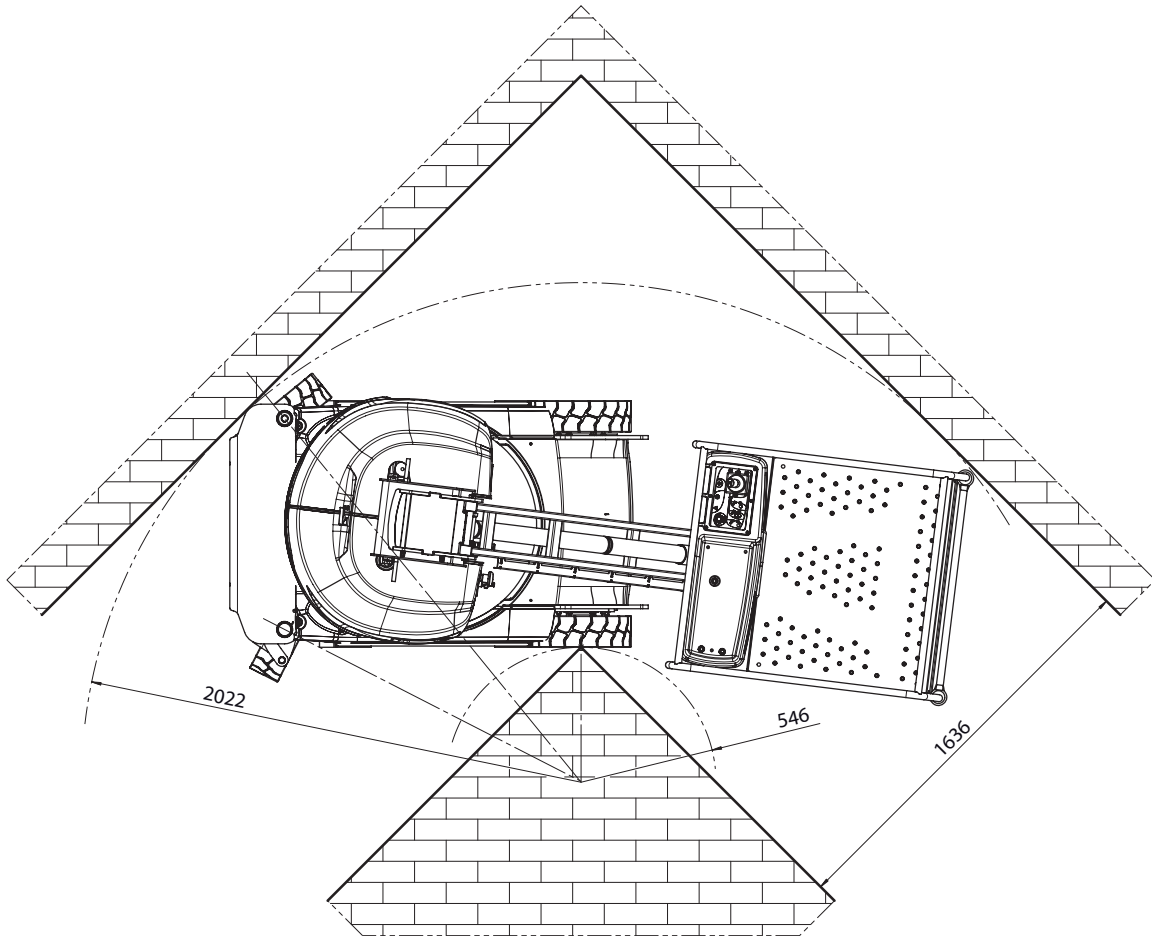
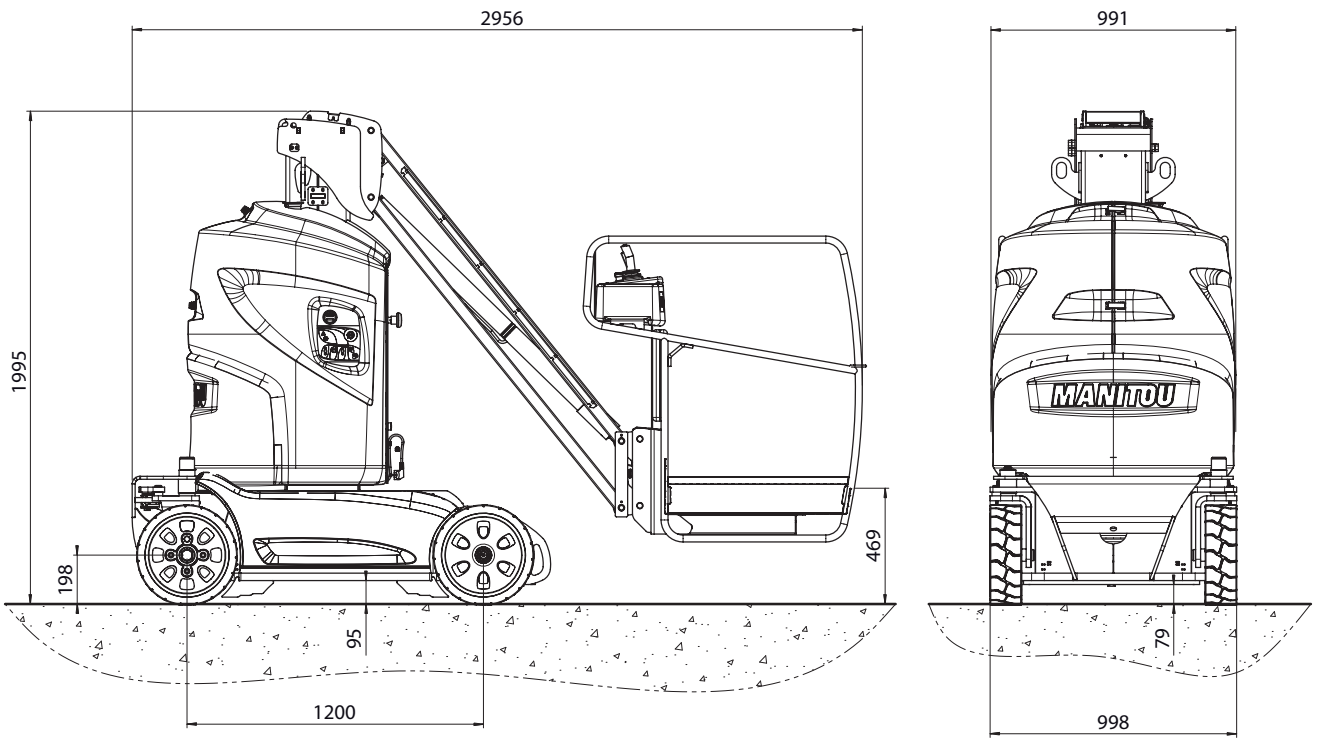

G1	1760
H1	5650
G2	2620
H2	4213
H2'	1623
G3	2020
H3	365

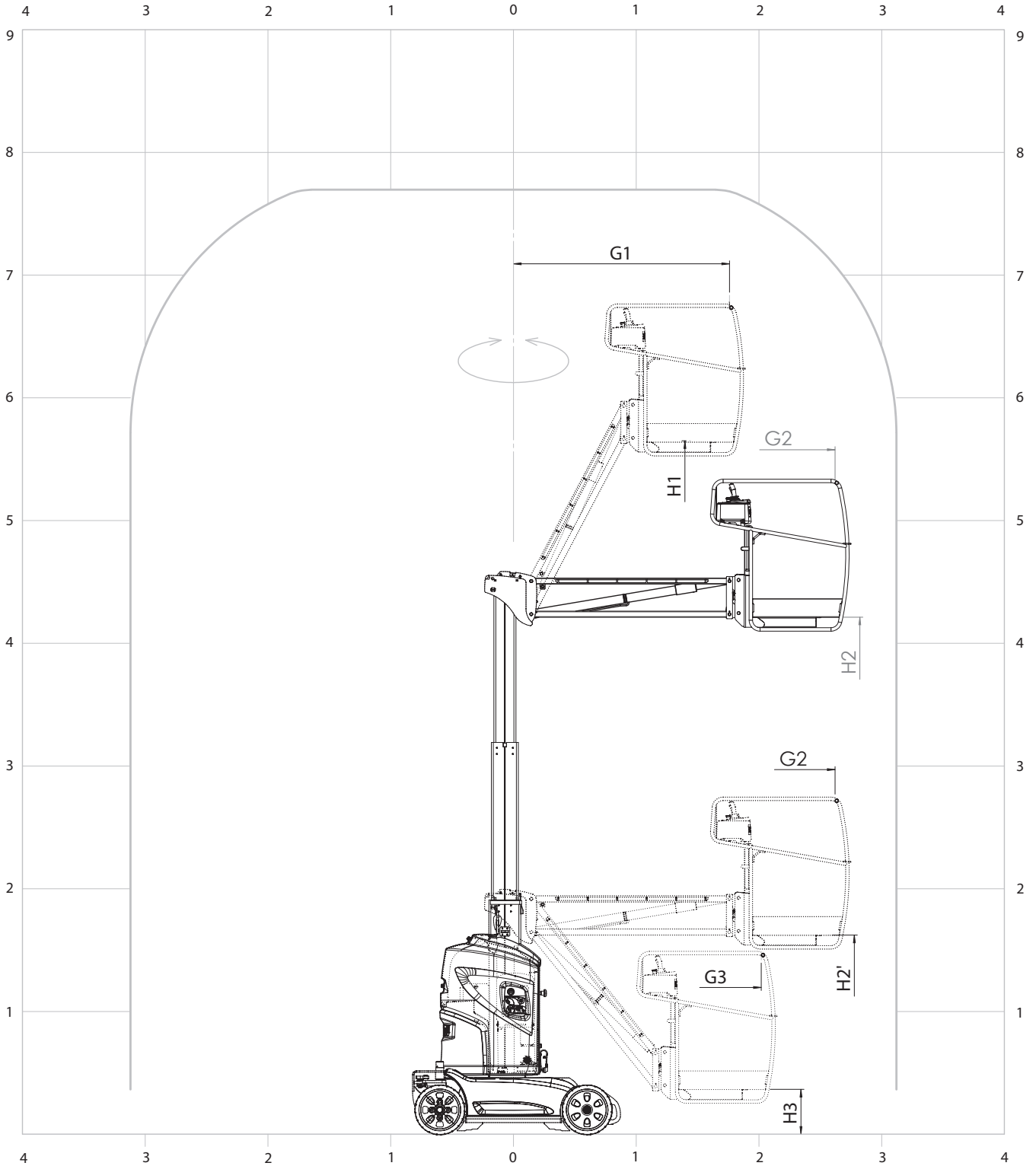

100 VJR WORKING DIMENSIONS

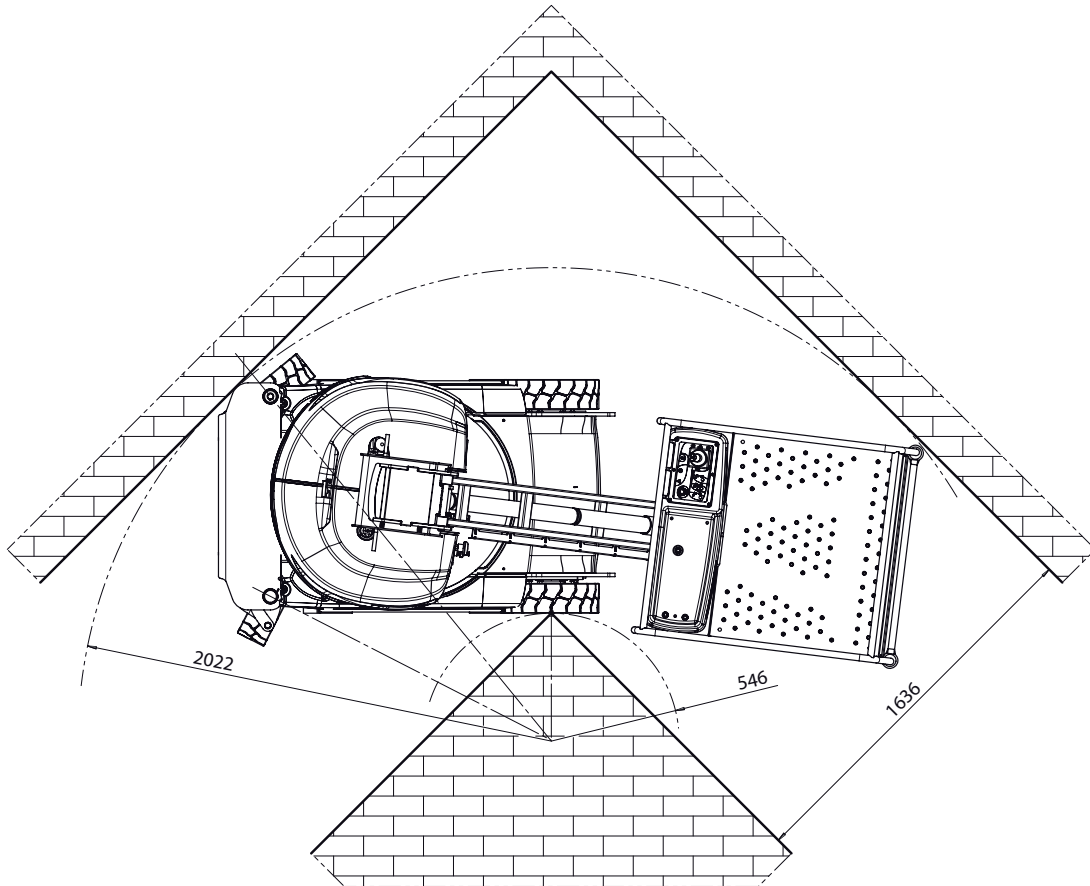
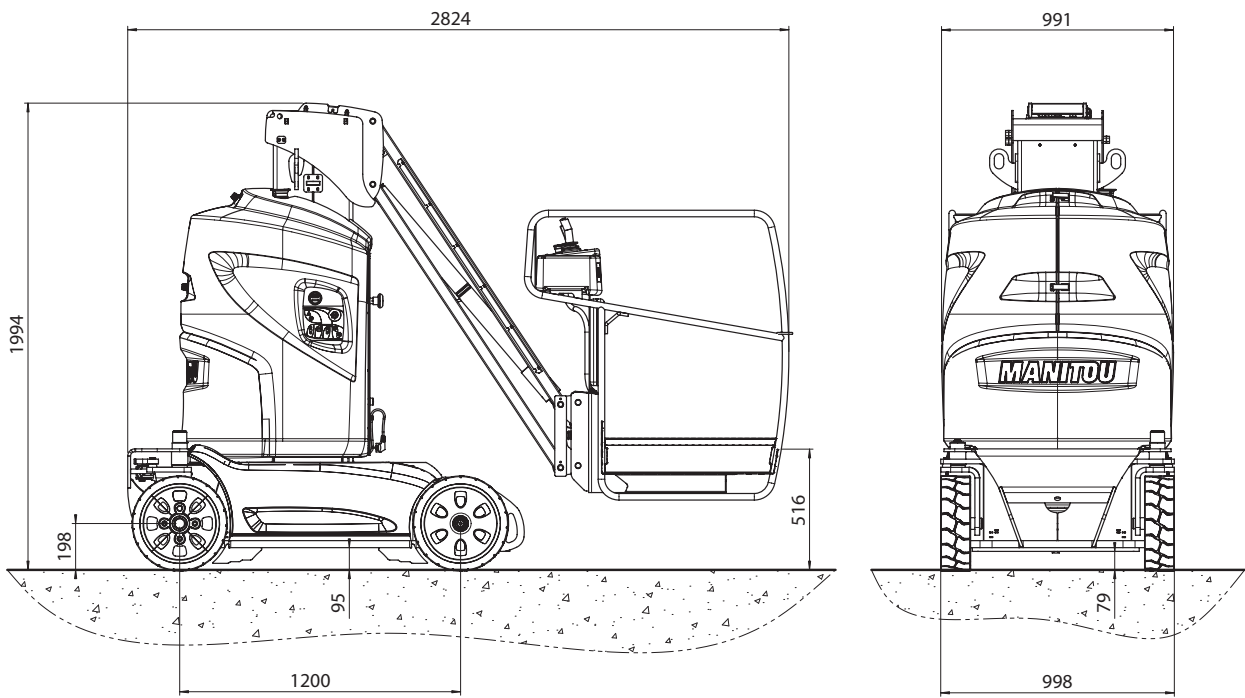

G1	1855
H1	7900
G2	2537
H2	6669
H2'	1623
G3	1888
H3	412

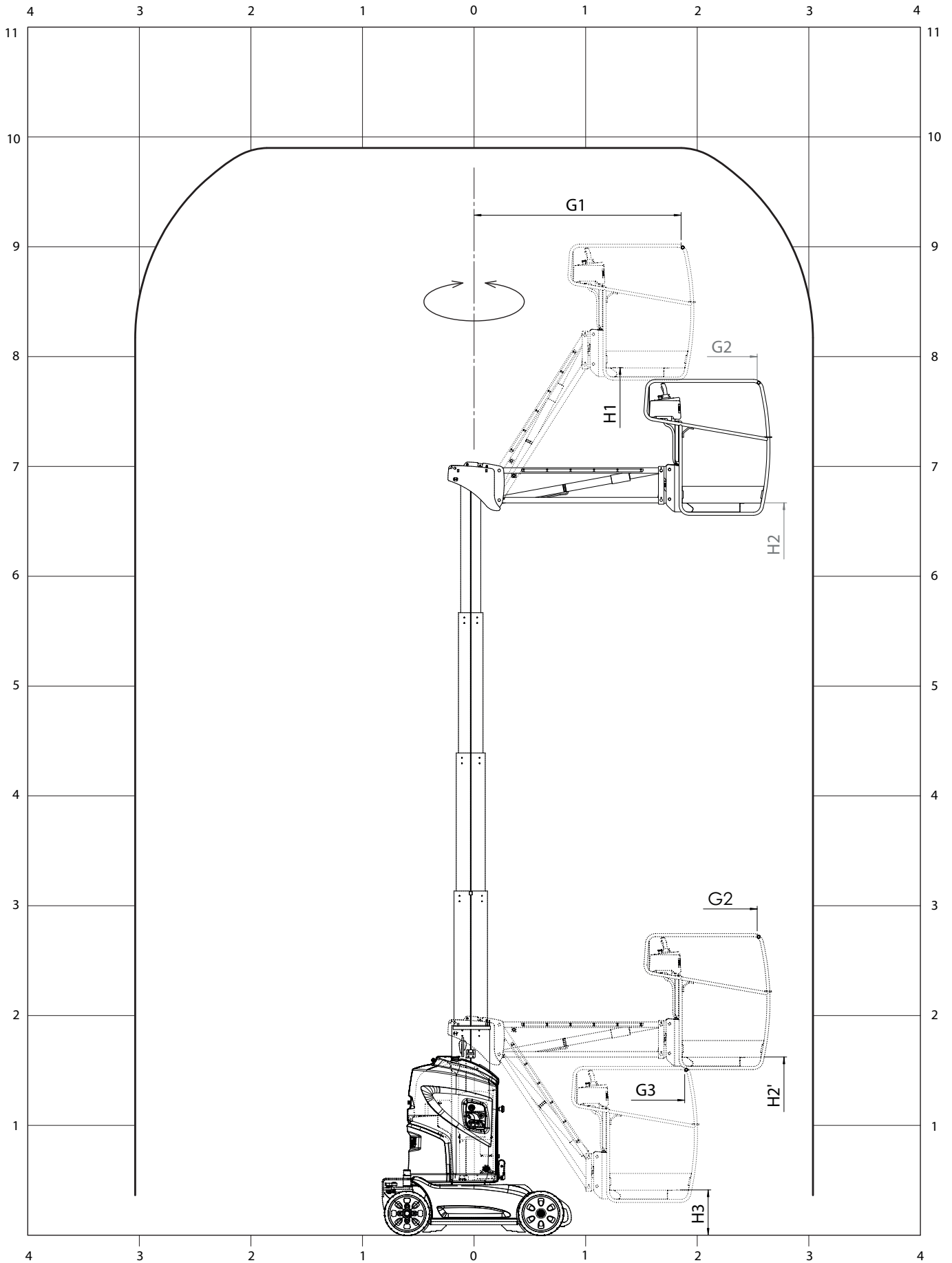

PLATFORM OPERATION

DESCRIPTION

- This machine is a mobile personnel lifting platform. It consists of an operating platform fixed on the end of a jib, itself fixed on the end of a telescopic mast, the whole mounted on a rotating turret.
- MANITOU lifting platforms are intended solely to be used for lifting people, and their tools and supplies (within authorized weight limits, see the "SPECIFICATIONS" chapter) to the desired operating height to reach hard-to-reach places above installations and buildings.
- The platform comprises a basket control station. From this control station, the operator can drive and operate the machine forwards or backwards. The operator can lift or lower the jib, extend or retract the telescope or rotate the turret. The basket, telescopic mast and turret assembly can rotate a total of 350 degrees, not continuously, to the right and to the left in relation to its retracted position.
- The platform also has a ground emergency and maintenance console from which all the lifting and rotation controls can be executed; translation is not possible from this console. The ground controls should only be used in an emergency to return the operator to the ground if he is unable to do so himself.
- The operator must make a daily inspection to ensure that the ground emergency and maintenance control console and the basket console are operating correctly.



Specifications, safety and rescue procedure stickers are affixed to the machine. The operator must familiarize himself with them and understand their content. To avoid incorrect interpretation of the pictograms, refer to the chapter "SAFETY STICKERS" in "1 - OPERATING AND SAFETY INSTRUCTIONS".

- The lifting platform's movements are provided by a hydraulic pump actuated by an electric motor, which is supplied by batteries. The hydraulic components are controlled by solenoid valves actuated by buttons and the control manipulator.
- The controls on the base and / or basket console, consisting of buttons, are either in On or Off mode.
- **The base console has a "dead man" function. A selector key must be pressed and held at the same time as a control key to activate a movement. The release of the selector key stops the movement (see the "INSTRUMENTS AND CONTROLS" chapter).**
- The lifting platform is a machine with two drive wheels driven by an electric motor on each wheel. The drive wheels have spring brakes with hydraulic release. These brakes are applied automatically when the translation manipulator is set to the neutral position.
- The lifting platform can lift to the limit of its capacities (see the "SPECIFICATIONS" chapter). A load of up to the maximum capacity in the basket will enable you to work in any position, provided the machine is not on an incline of more than 2°.

GENERAL

- The following pages give all the necessary information for use of the machine, including the procedures for using, driving, parking, loading and transporting the platform.

TILT

When the platform has reached the authorized maximum tilt (see the "SPECIFICATIONS" chapter):

- The indicator light 7 flashes steadily (ground emergency and maintenance station).
- The indicator light 17 flashes steadily (basket control station).
- The buzzer 23 sounds intermittently (basket control station).
- All the "AGGRAVATING" movements of raising the jib and extending the telescopic mast are forbidden as a safety measure.



To resume control, only make non-aggravating movements:
 - Return to the safe position by retracting the telescopic mast, lowering the jib and then repositioning the access platform on a more horizontal surface in order to be able to make lifting movements.

NOTE: the above references are the same as those used in the descriptions of these components on the following pages.

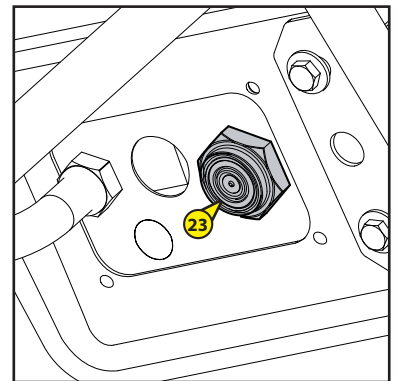
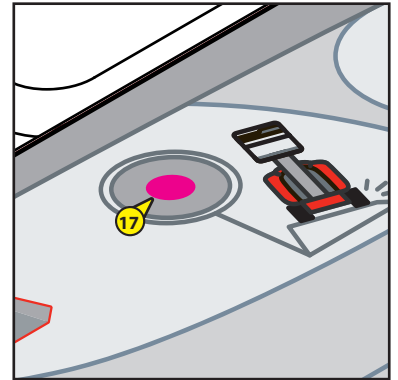
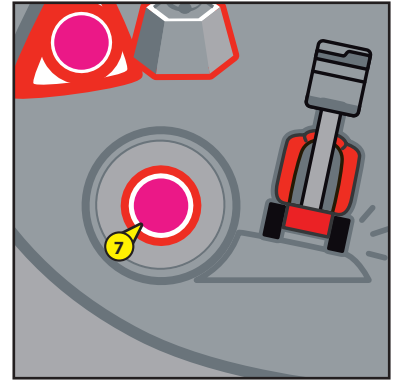

OVERLOAD

When the access platform reaches the authorized weight limit for the basket (see the "SPECIFICATIONS" chapter):

- The overload indicator light 8 flashes steadily (ground emergency and maintenance station).
- The overload indicator light ref. 16 flashes steadily (basket emergency and control station).
- The buzzer ref. 23 sounds continuously (basket emergency and control station).
- All movements are forbidden as a safety measure.



To recover control:
 - Relieve the weight on the basket by removing the item(s) causing the overload.
 OR
 - Ask someone on the ground to bring the basket down under manual control (see the end of the "Rescue procedure" in the chapter and "Safety stickers" in chapter "1 - Operating and safety instructions").

NOTE: the above references are the same as those used in the descriptions of these components on the following pages.

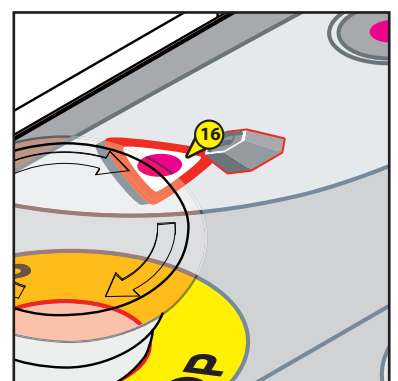
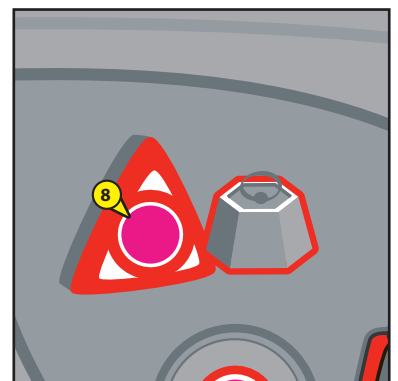

INSTRUMENTS AND CONTROLS

A - GROUND-BASED EMERGENCY AND MAINTENANCE STATION

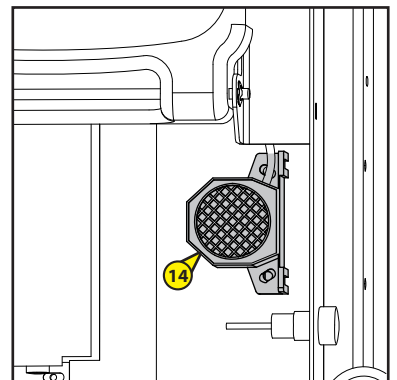
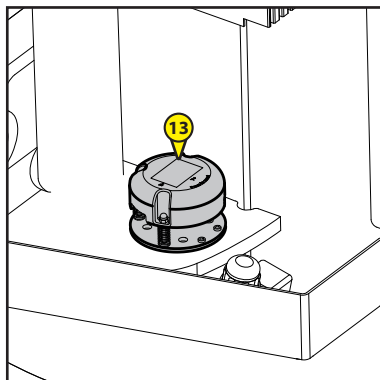
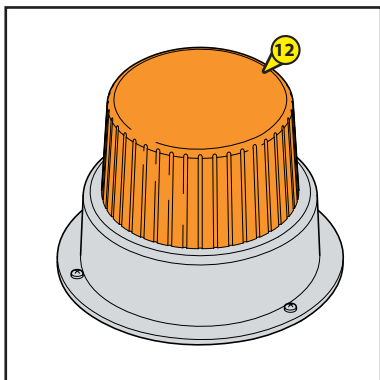
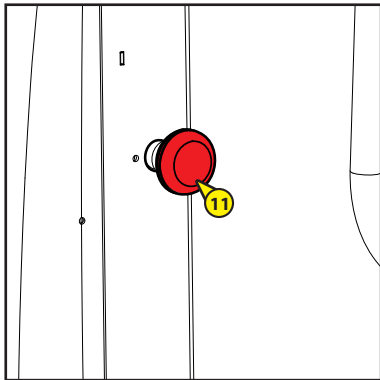
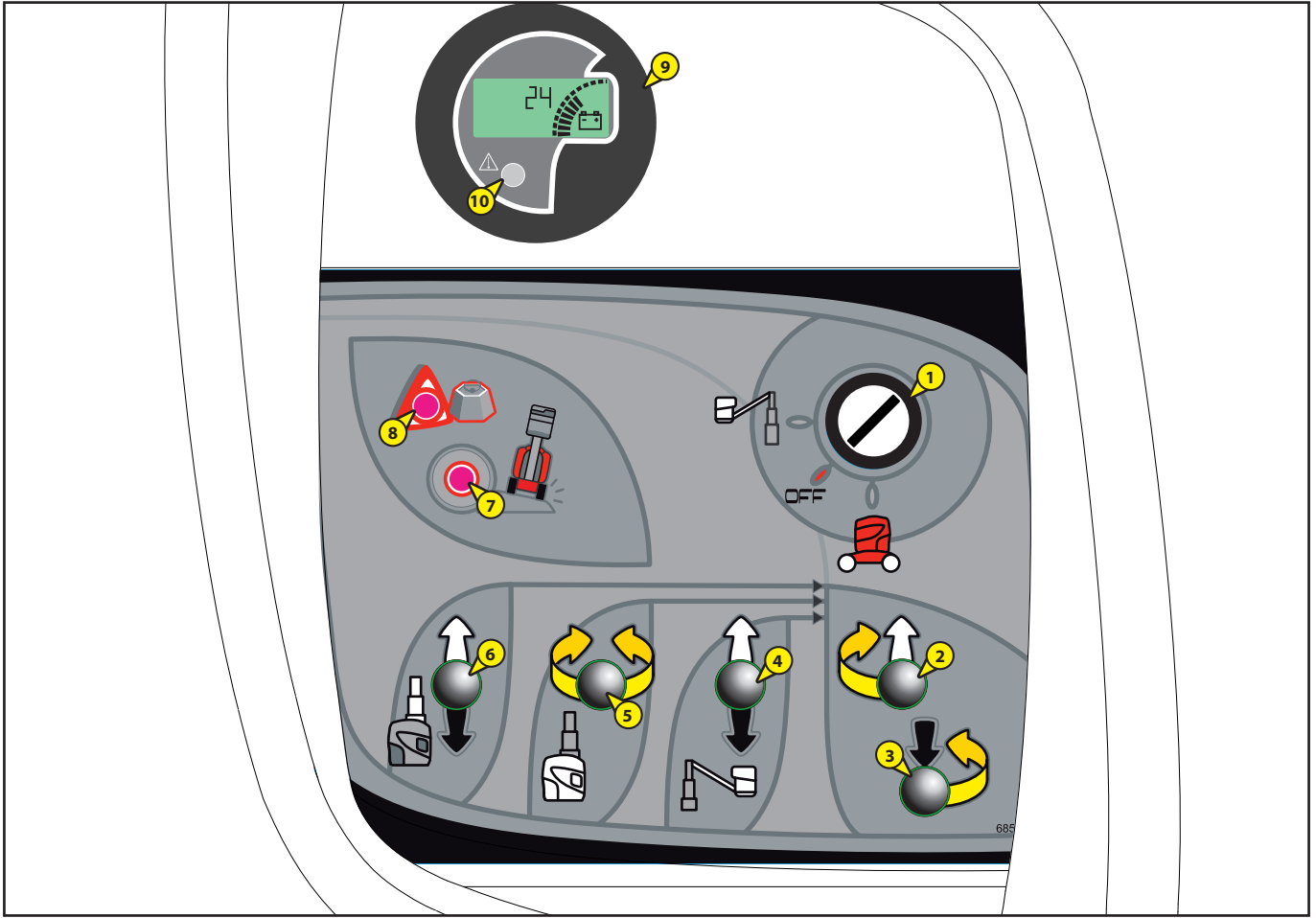

- 1 - GROUND / BASKET CONTROL KEY-OPERATED SELECTOR SWITCH**
- 2 - MAST ELEVATION, TURRET LEFT-HAND ROTATION OR JIB ELEVATION CONTROL BUTTON**
- 3 - MAST LOWERING, TURRET RIGHT-HAND ROTATION OR JIB LOWERING CONTROL BUTTON**
- 4 - JIB SELECTION BUTTON**
- 5 - TURRET ROTATION SELECTION BUTTON**
- 6 - MAST SELECTION BUTTON**
- 7 - TILT INDICATOR LIGHT**
- 8 - OVERLOAD INDICATOR LIGHT**
- 9 - BATTERY CHARGE INDICATOR AND ACCESS PLATFORM HOUR METER**
- 10 - "MACHINE FAULT" INDICATOR LIGHT**
- 11 - EMERGENCY STOP AND/OR BATTERY CUT-OFF BUTTON**
- 12 - FLASHING LIGHT (OPTION)**
- 13 - TILT SENSOR**
- 14 - HORN**

B - BASKET COMMAND AND CONTROL STATION

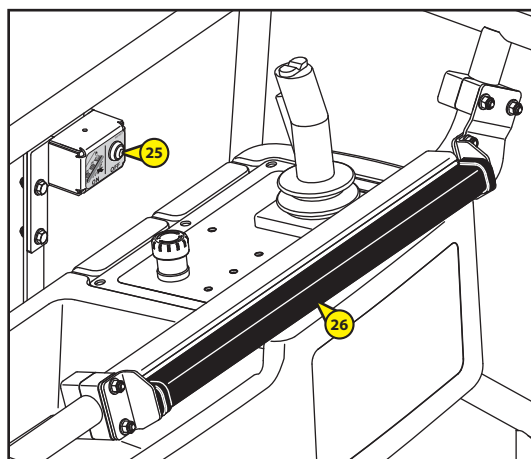
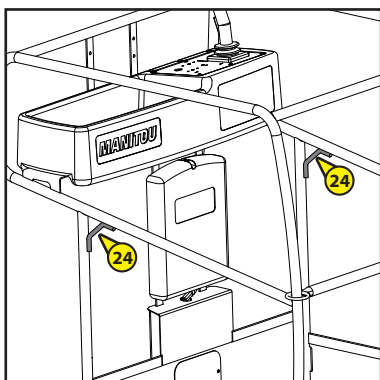
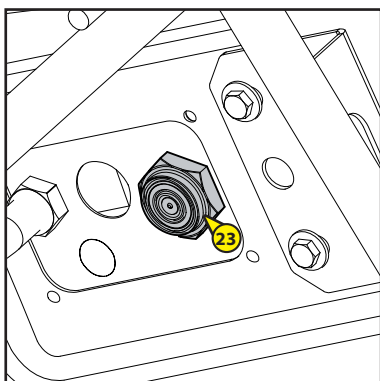
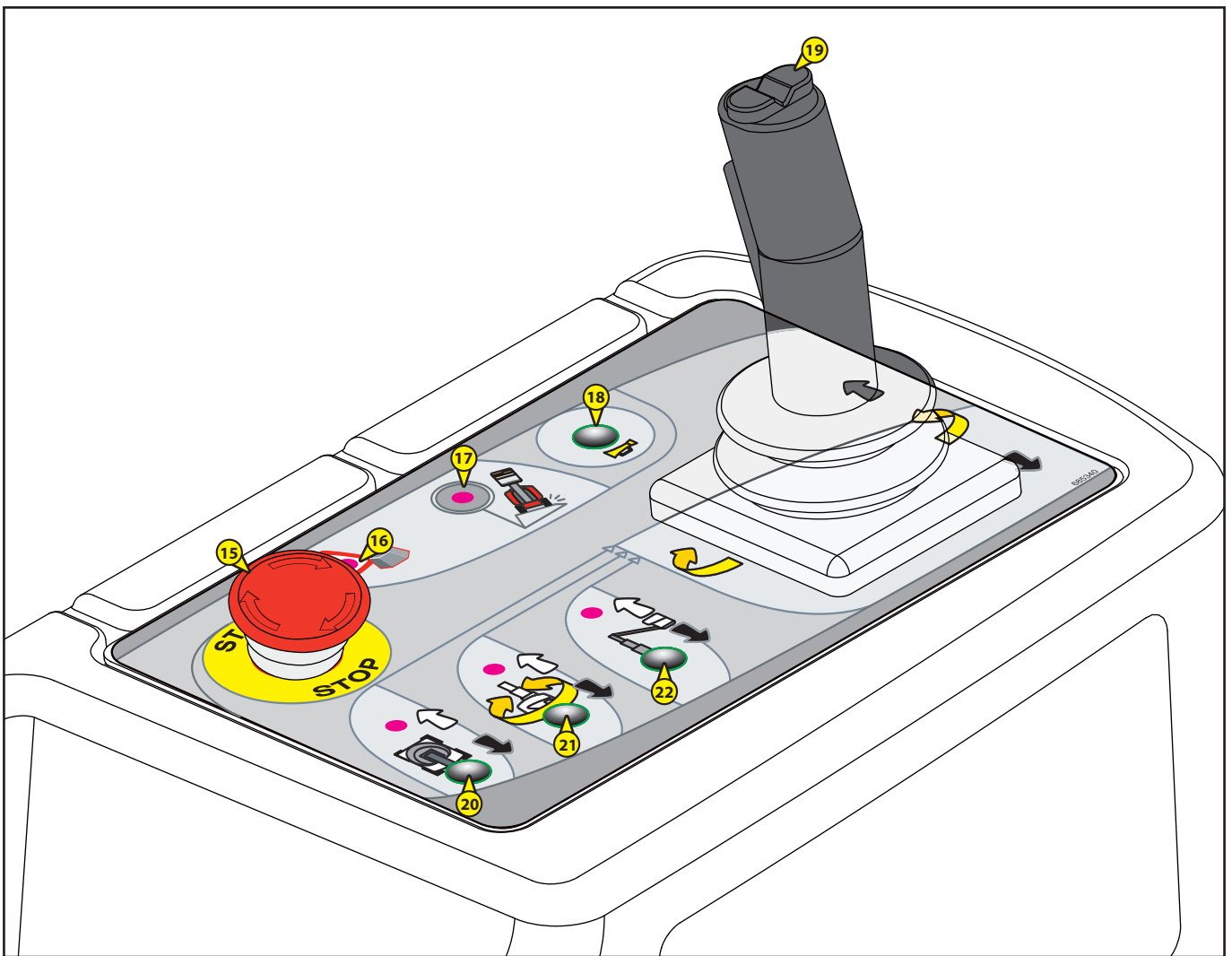

15 - EMERGENCY STOP BUTTON

16 - OVERLOAD INDICATOR LIGHT

17 - TILT INDICATOR LIGHT

18 - HORN BUTTON

19 - MANIPULATOR

20 - TRAVEL CONTROL BUTTON

21 - TURRET ROTATION, MAST ELEVATION AND LOWERING CONTROL BUTTON

22 - JIB ELEVATION AND LOWERING BUTTON

23 - VIBRATING BUZZER

24 - SAFETY HARNESS ATTACHMENT POINTS

25 - RESET BUTTON (SAFEMANSYSTEM OPTION)

26 - SAFETY EDGE (SAFEMANSYSTEM OPTION)

27 - BLUE FLASHING LIGHT (OPTION)

NOTE: The terms RIGHT-LEFT-FRONT-REAR are understood to be for an operator looking forwards from the basket while it is in transport position.

GROUND EMERGENCY AND MAINTENANCE CONSOLE

1 - GROUND / BASKET CONTROL KEY-OPERATED SELECTOR SWITCH

This selector has three positions; the central position is the OFF position.

Position A:

- The commands are issued from the basket control console.

Position B:

- Neutral position, the controls for the access platform are receiving no power (remove the key in this position).

Position C:

- The commands are issued from the ground emergency and maintenance console.

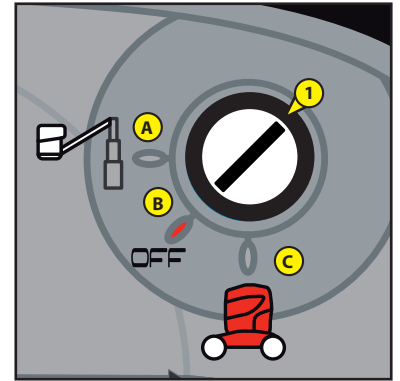

2 - MAST ELEVATION, TURRET LEFT-HAND ROTATION OR JIB ELEVATION CONTROL BUTTON

By pressing this control button 2 and one of the selection buttons simultaneously, you will:

- Elevate the telescopic mast, rotate the turret to the left or elevate the jib.

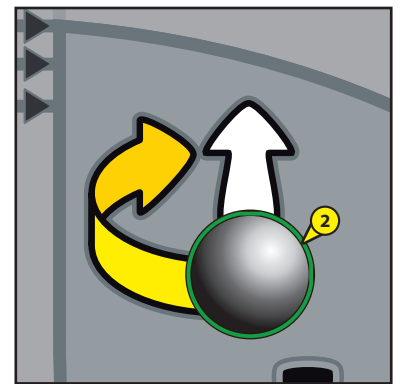

3 - MAST LOWERING, TURRET RIGHT-HAND ROTATION OR JIB LOWERING CONTROL BUTTON

By pressing this control button 3 and one of the selection buttons simultaneously, you will:

- Lower the telescopic mast, rotate the turret to the right or lower the jib.

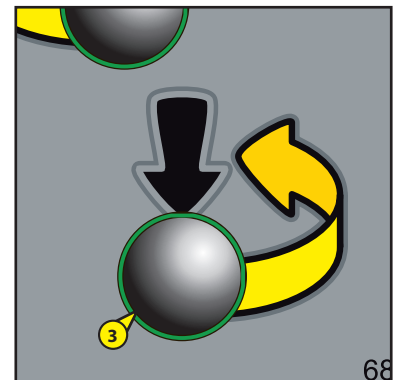

4 - JIB SELECTION BUTTON

Elevating the jib:

- Press the selection button 4 and the control button 2 to raise the jib.

Lowering the jib:

- Press the selection button 4 and the control button 3 to lower the jib.

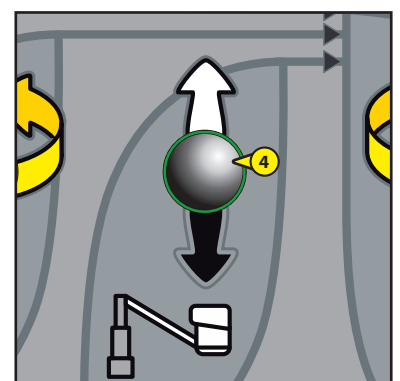

5 - TURRET ROTATION SELECTION BUTTON

Left-hand turret rotation:

- Press the selection button 5 and the control button 2 to rotate the turret to the left.

Right-hand turret rotation:

- Press the selection button 5 and the control button 3 to rotate the turret to the right.

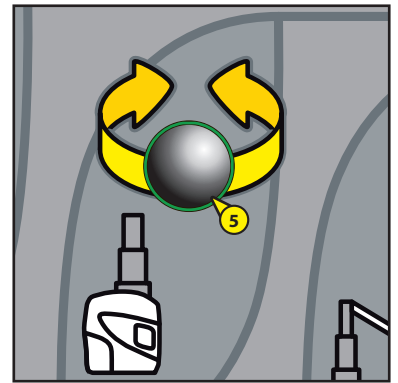

6 - MAST SELECTION BUTTON

Telescopic mast elevation:

- Press the selection button 6 and the control button 2 to raise the telescopic mast.

Telescopic mast lowering:

- Press the selection button 6 and the control button 3 to lower the telescopic mast.

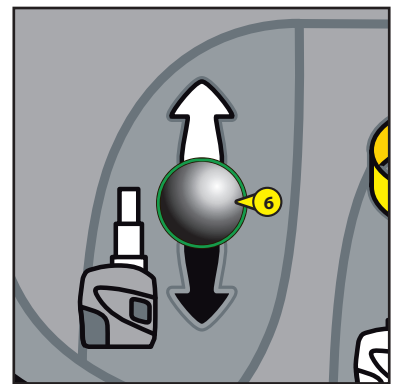

7 - TILT INDICATOR LIGHT

When the access platform reaches the maximum authorized tilt, the indicator light 7 flashes steadily (see the "HOW TO OPERATE THE ACCESS PLATFORM - SAFETY ADVICE" chapter).

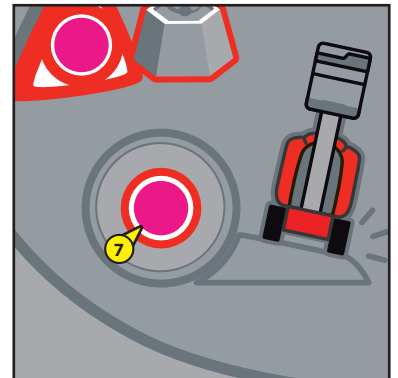

8 - OVERLOAD INDICATOR LIGHT

If there is an overload in the basket, indicator light 8 flashes steadily (see the "HOW TO OPERATE THE ACCESS PLATFORM - SAFETY ADVICE" chapter).

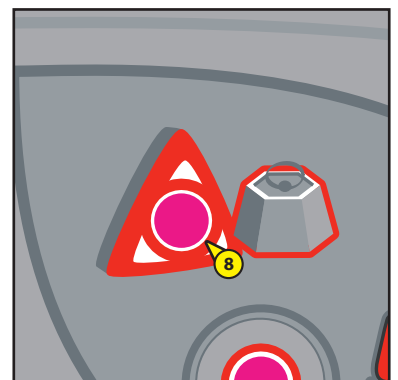

9 - BATTERY CHARGE INDICATOR AND ACCESS PLATFORM HOUR METER

A - BATTERY CHARGE INDICATOR:

Battery charged:

- All the bars are displayed (blackened).

Battery discharged:

- Only two bars are displayed, so the batteries need to be recharged (see "3 - MAINTENANCE").

NOTE: The battery charge level must not drop below the 20% charge level, otherwise there is the risk of rapid and irreversible damage to the batteries.

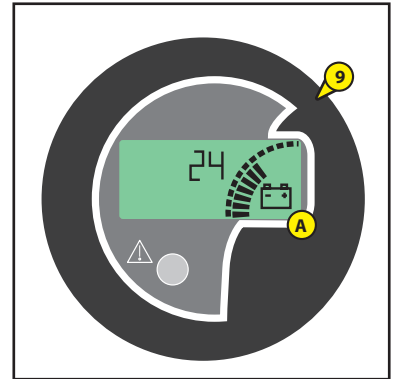

B - DAILY HOUR METER INDICATOR

This shows the total number of hours for all the movements made and can be reset to zero.

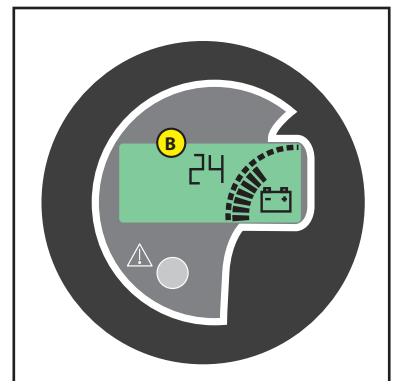

10 - "MACHINE FAULT" INDICATOR LIGHT

This indicator light informs us that there is a machine fault:

- Hour meter



- Speed



- Maintenance alarm



11 - EMERGENCY STOP AND/OR BATTERY CUT-OFF BUTTON

This red mushroom-head circuit breaker enables you to cut off all the machine's movements in the event of an anomaly or danger arising.

- Press the knob to cut off the movements.
- Pull the knob to restore the power supply (the switch returns automatically to its initial position).



In all cases this control takes priority, even if the movements are executed from the basket control console. When the Emergency Stop button is activated, the movements can stop very abruptly.



Do not use the emergency stop button to simply stop the access platform, otherwise reset it as quickly as possible as no action can be carried out from the basket console.

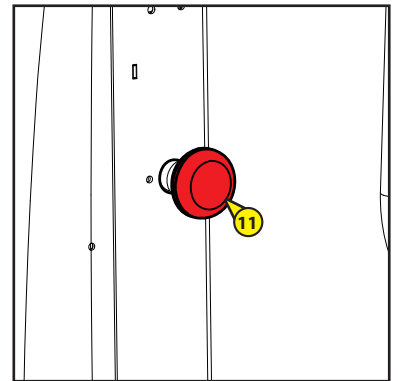

12 - FLASHING LIGHT (OPTION)

The rotating beacon light illuminates automatically when the access platform is performing a translation or a movement (raising, rotating, etc.).

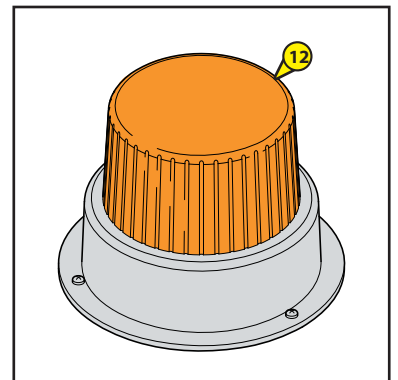

13 - TILT SENSOR

This sensor controls the platform's tilt. When the platform has reached the maximum permitted tilt (see the "SPECIFICATIONS" chapter), the buzzer 23 sounds intermittently and all the "AGGRAVATING" movements involving elevation of the jib and telescopic mast are blocked. (See the "HOW TO OPERATE THE ACCESS PLATFORM - SAFETY ADVICE" chapter).

TILT TEST: place the platform on flat ground, with the key switch 1 in the ground emergency and control console position, press the "PRESS TO TEST" button: the buzzer should sound and the warning light should come on.



During the test, if the buzzer remains silent and the warning light remains extinguished, immobilize the platform and carry out the necessary repairs.

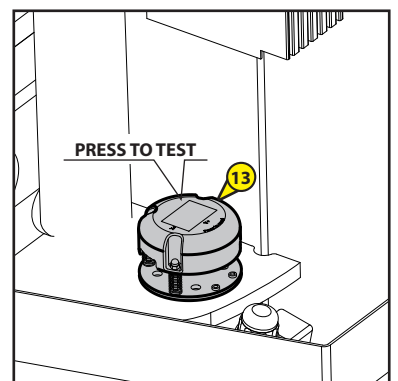

14 - HORN

The horn is mounted on the turret below the ground emergency and maintenance console; it is activated by pressing the button 18.

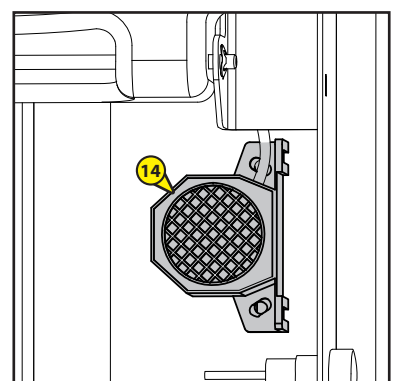

15 - EMERGENCY STOP BUTTON

This red mushroom-head button enables you to cut off all the basket control consoles movements in the event of an anomaly or danger arising.

- Press the emergency stop button to cut off the movements controlled from the basket console.
- Turn the knob a quarter of a turn to the right to restore the power supply (the switch returns automatically to its initial position).



This command has priority under all circumstances, except when movements are controlled from the ground emergency and maintenance console.



Do not use the emergency stop button to simply stop the access platform, otherwise reset it as quickly as possible as no action can be carried out from the basket console.



To lower to the ground in spite of the emergency stop activated, use the controls on the ground emergency and maintenance console (see the "RESCUE PROCEDURE" chapter).

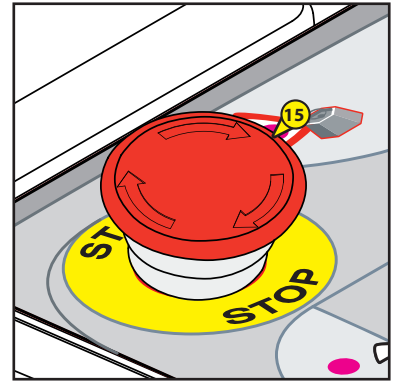

16 - OVERLOAD INDICATOR LIGHT

If there is an overload in the basket, the indicator light 16 flashes steadily (see the "HOW TO OPERATE THE ACCESS PLATFORM - SAFETY ADVICE" chapter).

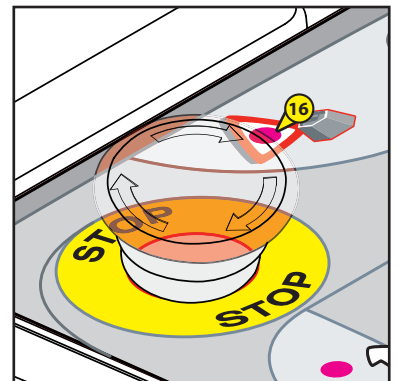

17 - TILT INDICATOR LIGHT

When the access platform reaches the maximum authorized tilt, the indicator light ref. 17 flashes steadily (see the "HOW TO OPERATE THE ACCESS PLATFORM - SAFETY ADVICE" chapter).

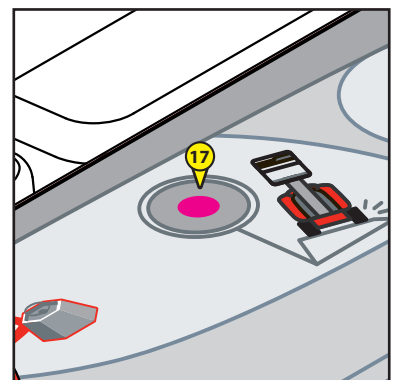

18 - HORN BUTTON

By pressing this button 18, the horn 14 is activated.

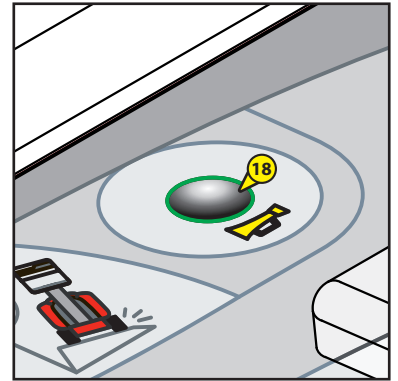

19 - MANIPULATOR

NOTE: This manipulator is controlled gradually, which enables a highly precise approach. It should be operated smoothly, without jerks.



SAFETY TRIGGER:

The trigger A on the manipulator 19 must be continuously pressed down to make any movements from the access platform's control box.

TRANSLATION: see ref. 20.

STEERING:

Turn to the left or right without a translation movement:

- Select translation movement by pressing the button 20.
- Select the direction by pressing and holding down the button B or C of the manipulator 19 to the left or right to turn the wheels to the left or right respectively.

Turn to the left or right with a translation movement:

- Select translation movement by pressing the button 20.
- Select the direction by pressing and holding down the button B or C of the manipulator 19 to the left or right to turn the wheels to the left or right respectively.
- Push the manipulator 19 forwards or pull it backwards respectively to move forward or back while turning the wheels.

TURRET ROTATION: see ref. 21.

ELEVATION OR LOWERING OF THE TELESCOPIC MAST: see ref. 21.

ELEVATION OR LOWERING OF THE JIB: see ref. 22.

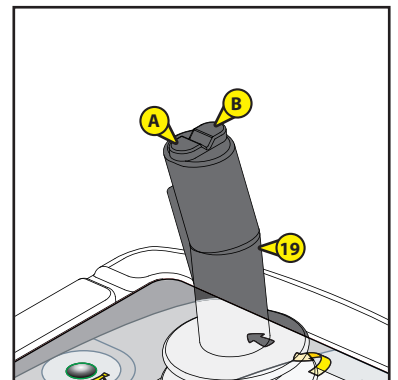
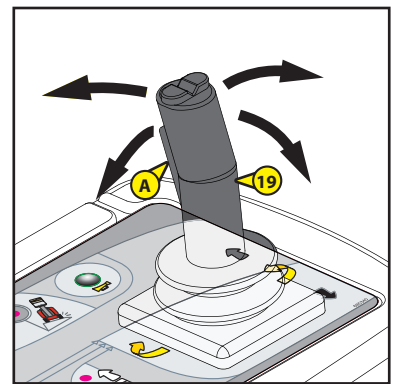

20 - TRAVEL CONTROL BUTTON

Select translation movement by pressing the button 20.

- Push the manipulator 19 forwards or pull it backwards respectively to travel forwards or backwards.

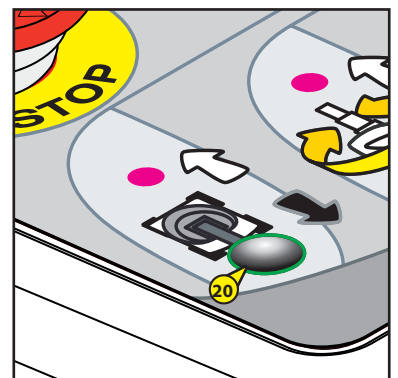

21 - TURRET ROTATION, MAST RAISING OR LOWERING CONTROL BUTTON

Select turret rotation or the telescopic mast raising or lowering movement by pressing the button 21.

- Tilt the manipulator 19 to the left or right to rotate the turret to the left or right.
- Push the manipulator 19 forwards or pull it backwards respectively to raise or lower the telescopic mast.

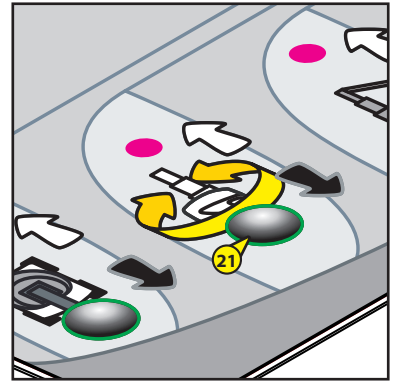

22 - JIB ELEVATION OR LOWERING BUTTON

Select the jib elevation or lowering movement by pressing the button 22.

- Push the manipulator 19 forwards or pull it backwards respectively to elevate or lower the jib.

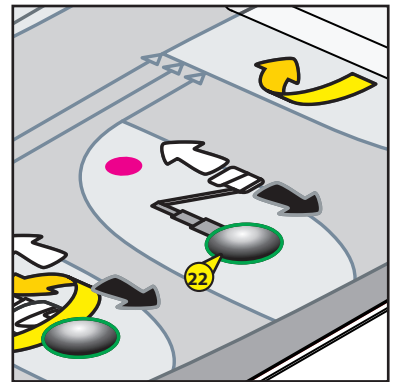

23 - VIBRATING BUZZER

This vibrating buzzer 23 is activated when the machine is in one of the two following critical situations:

- **TILT: discontinuous buzzer**
(See the "HOW TO OPERATE THE ACCESS PLATFORM: SAFETY ADVICE") chapter
- **OVERLOAD: continuous buzzer**
(See the "HOW TO OPERATE THE ACCESS PLATFORM - SAFETY ADVICE") chapter

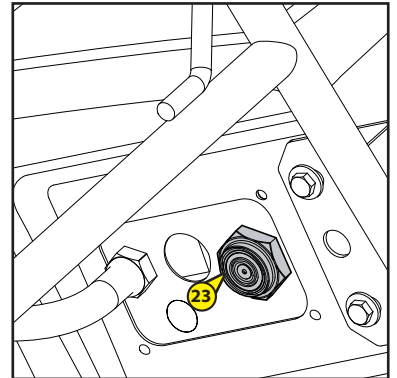

24 - SAFETY HARNESS ATTACHMENT POINTS

These attachment points 24 are used to fasten the harness when the operators are in the basket (see "1 - OPERATING AND SAFETY INSTRUCTIONS").

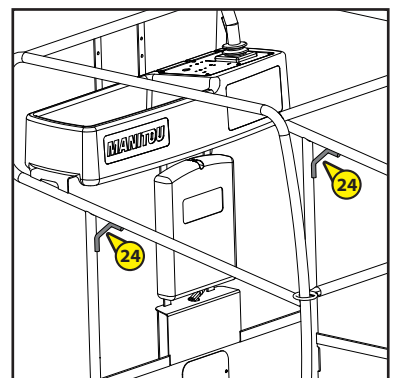

25 - RESET BUTTON (SAFEManSYSTEM OPTION)

See the "DESCRIPTION AND USE OF THE OPTIONS" chapter.

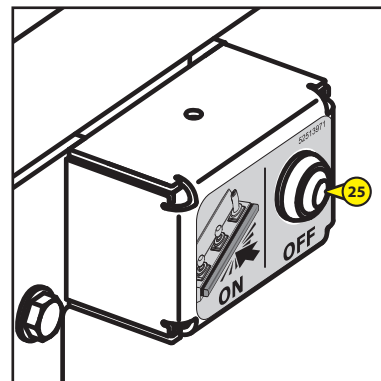

26 - SAFETY EDGE (SAFEManSYSTEM OPTION)

See the "DESCRIPTION AND USE OF THE OPTIONS" chapter.

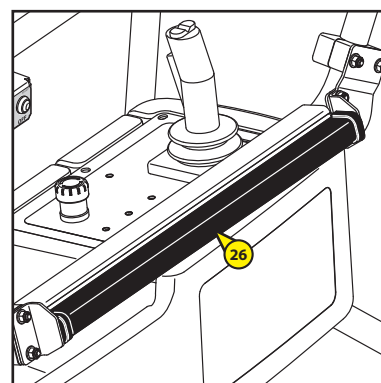

27 - BLUE FLASHING LIGHT (SAFEManSYSTEM OPTION)

See the "DESCRIPTION AND USE OF THE OPTIONS" chapter.



USING THE PLATFORM

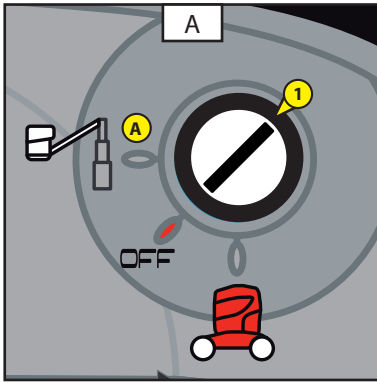

MOVING IN TRANSPORT / OPERATING MODE

Before transport and use, select position A on the key switch 1 (Fig. A) (controls from the basket control console).

The access platform has two distinct modes of movement: transport (Fig. C) and operating mode (Fig. D) (forward direction (Fig. B)).

- Transport mode (Fig. C): the telescopic mast and jib must be in the lowered position. This mode permits movement at high speed, and movement in excess of the machine's tilt (see the "SPECIFICATIONS" chapter).
- Working mode (Fig. D): when the telescopic mast is extended or the jib elevated, travel movements are performed at slow speed and the tilt and overload safety interlocks are enabled.

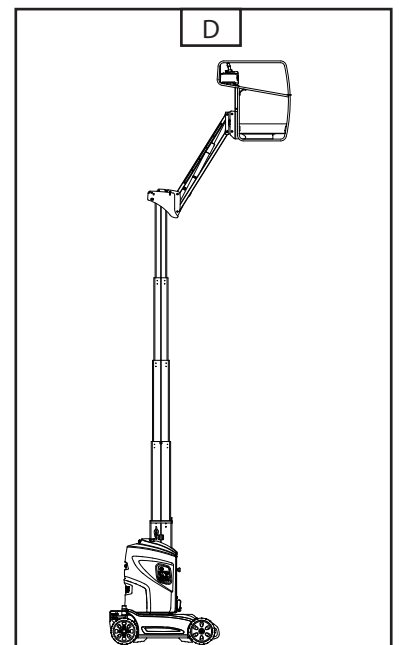
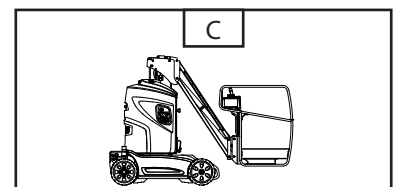

No movements are to be performed on sloping ground with a gradient that exceeds the authorized tilt (see the "SPECIFICATIONS" chapter) or unevenness that could rock the platform.



Before driving the access platform, ensure that the basket control console is correctly located over the drive wheels; if it is over the steering wheels, the controls will be reversed relative to the direction of the machine.

TRANSPORT SPEED / OPERATING SPEED LIMITS

The jib can be raised and lowered in transport speed mode.

INSTALLATION IN THE WORKPLACE AND LIFTING

The access platform has been designed to work on a flat, horizontal surface: it is important to clear the area in which the access platform must work.



Familiarize yourself with the instruments on the ground emergency and maintenance console and the basket console described in the preceding pages and in particular the warnings specifying the risks associated with performing certain maneuvers.

- Bring the access platform to the workplace.
- If necessary, load the equipment and supplies and distribute the load evenly (stack it in a manner so as not to inconvenience the operator and avoid anything falling off).
- Climb into the basket.



We strongly recommend that you wear a safety helmet and a harness.



When maneuvering the platform (lifting, rotation, etc.), look around and above you. Pay particular attention to electrical cables and any object that may be within the access platform's field of operation.

LOWERING

Once work is completed: lower the telescopic mast and lower the jib to bring the access platform into the transport position.



Pay attention to people on the ground when lowering the basket.

STOPPING THE ACCESS PLATFORM

When the access platform is not being used, switch off the electrical power supply by positioning the key-operated switch in the Neutral position (see KEY-OPERATOR SWITCH 1).

At the end of the day: recharge the battery as needed (see "3 - MAINTENANCE").



Always set the battery cut-off to the OFF position when you are no longer using the access platform.



Check that the safety instructions associated with the flatbed have been correctly applied before loading the access platform and ensure that the driver of the vehicle has been informed of the dimensional characteristics and weight of the platform (see the "SPECIFICATIONS" chapter).

When being loaded onto a flatbed, the access platform must be in transport position:

- Counterweight facing the ramp (counterweight over the access platform's steering wheels) (Fig. A), see "1 - OPERATING AND SAFETY INSTRUCTIONS".
- Telescopic mast retracted.
- The jib can be raised so as not to touch the ground, but it is not recommended to perform any translational movements with the basket excessively raised. It should be kept in the lowest possible position while manoeuvring (fall or impact hazard, see "1 - OPERATING AND SAFETY INSTRUCTIONS").



Ensure that the flatbed is of sufficient size and load capacity for transporting the access platform. Check also the allowable ground contact pressure of the flatbed relative to the platform.

LOADING

- Lock the wheels of the flatbed transporter (Fig. B).
- Fasten the loading ramps to the truck bed so as to obtain the shallowest possible angle for the access platform to climb.

SECURING THE PLATFORM

There are two possible methods of tying-down the access platform (according to model).

TYING-DOWN BY MEANS OF THE FRAME (all models):

- Attach the chocks (1) to the truck bed at the front and at the rear of each wheel of the access platform (Fig. B).
- Also attach the chocks (2) to the flatbed on the outside of each wheel (Fig. C).
- Tie the access platform down to the flatbed with chains or sufficiently strong straps (3) at the front and rear by threading them through the tie-down points on the frame (Fig. C), see "1 - SAFETY STICKERS: TIE-DOWN POINT".

TYING-DOWN BY MEANS OF THE TELESCOPIC MAST (according to model):

- Attach the chocks (1) to the truck bed at the front and at the rear of each wheel of the access platform (Fig. B).
- Also attach the chocks (2) to the truck bed on the outside of each wheel (Fig. D).
- Tie the access platform down to the flatbed on the left- and right-hand sides with sufficiently strong straps (4), threading them through the tie-down points of the telescopic mast (Fig. D and E), see "1 - SAFETY STICKERS: TIE-DOWN POINT".

UNLOADING:



Never descend from a truck in the forwards direction (with the counterweight forward over the steering wheels); the rear wheels' low adherence make the braking less efficient.



Adapt the access platform's travel speed by controlling it with the travel joystick.

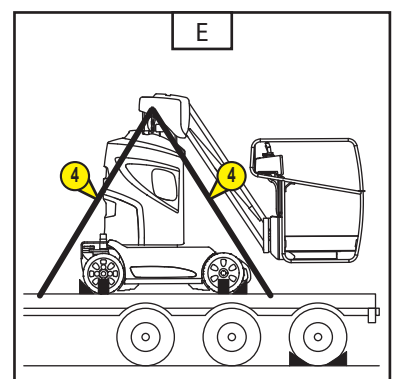
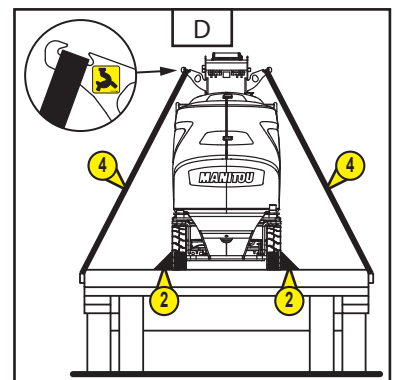
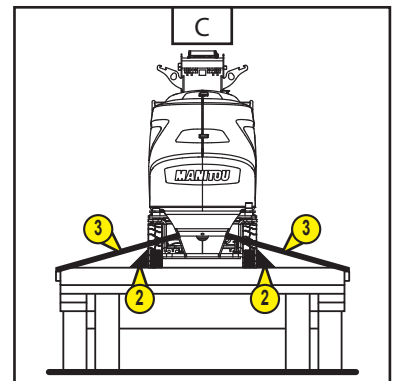
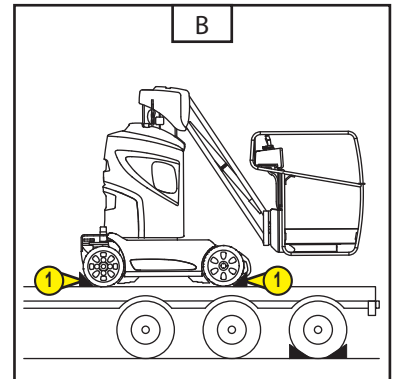
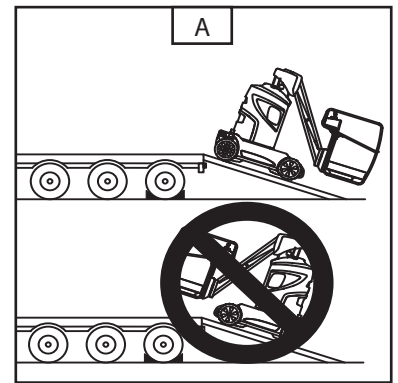

RESCUE PROCEDURE

This section describes the procedures to follow and the controls to be used in the event of a problem (if the access platform breaks down or there is a person stuck in the basket) while the access platform is being used. When first taking over the machine and regularly thereafter, this procedure must be read and thoroughly understood by the operator and all the people whose duties are centered on activities in contact with the machine.

IN THE EVENT OF OPERATOR INDISPOSITION

If the operator should fall ill, accidentally trigger the basket emergency stop button, or find himself incapable of maneuvering, the person present on the ground can take over control from the ground emergency and maintenance station; follow the instructions below:

- Select position C on the key-operated switch 1 (Fig. A) to recover control of the platform's movements.
- Proceed to lower the access platform.



Pay attention to any constructions or objects that may be under the access platform.

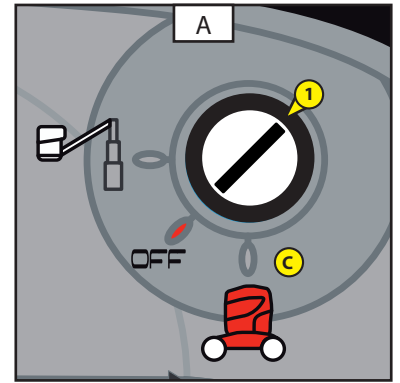

IN THE EVENT OF AN ACCIDENT OR A BREAKDOWN

Evacuate the people in the basket. If an accident or breakdown occurs making the electrical control boxes unusable, the machine is provided with systems for making all the movements manually.

- Open the turret covers and follow the procedures indicated on the stickers.

A diagram of the telescope lowering procedure is shown below.

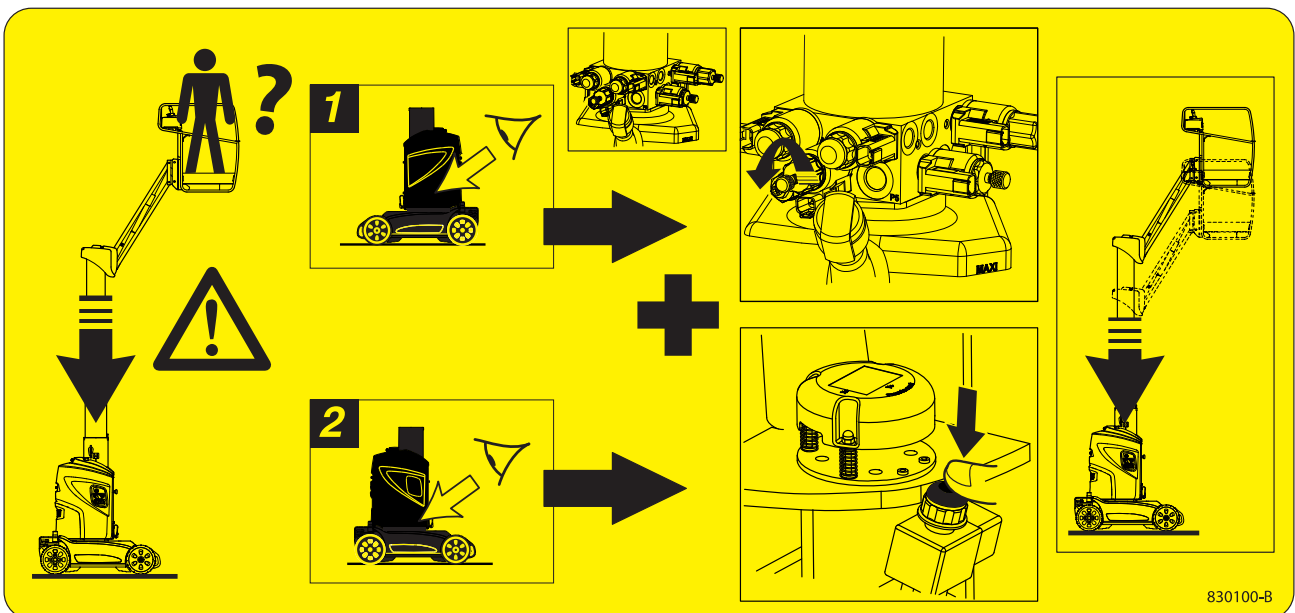

A diagram of the emergency procedure is shown below.

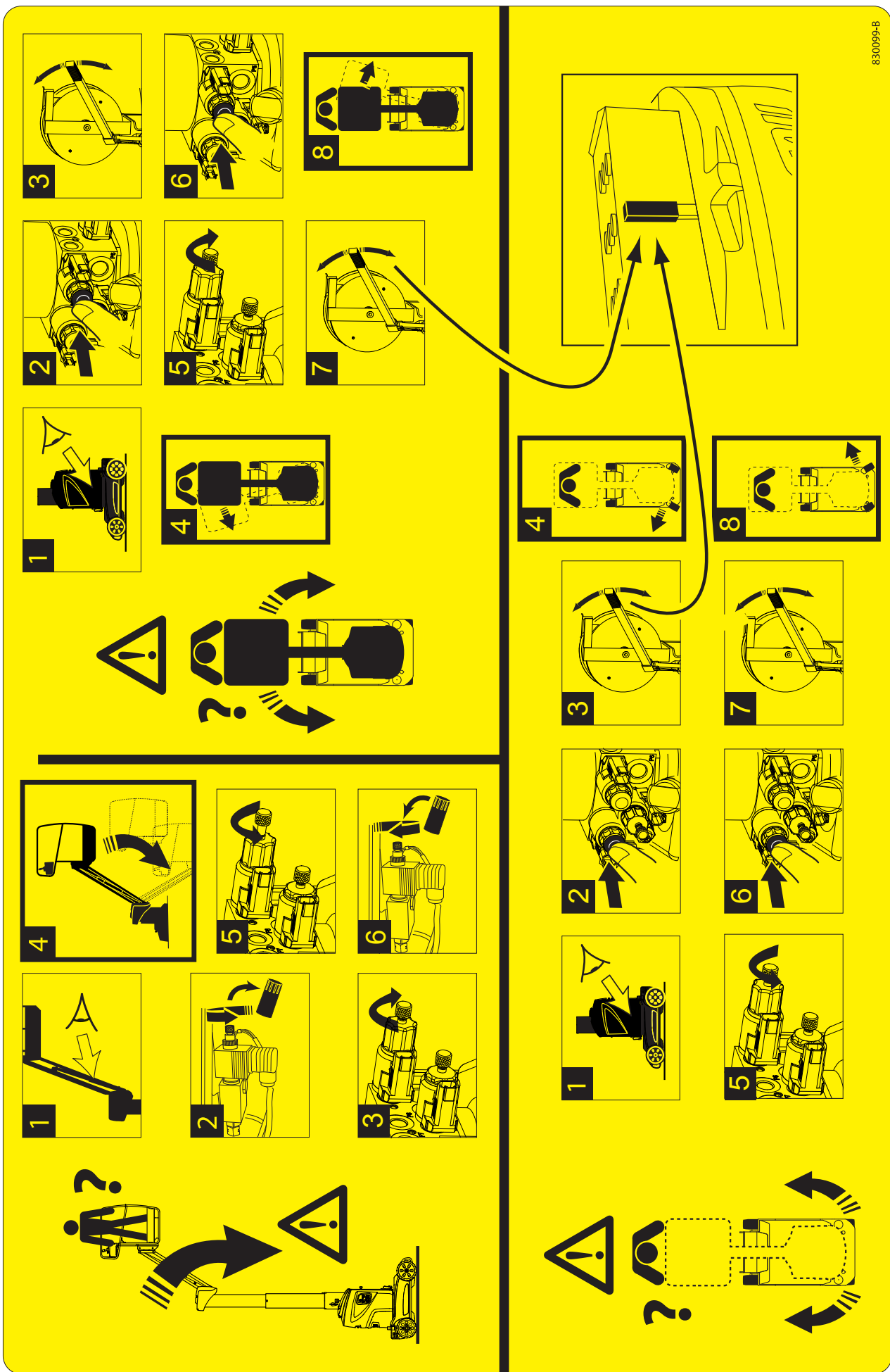

FREEWHEELING PROCEDURE

- Attach the access platform to a vehicle that can tow it and restrain it.
 - Locate the freewheeling switch on the ground emergency and maintenance console (Fig. A).
 - Depending on the model:
 - Turn the switch 1 to the right (Fig. B) to set the machine to freewheeling. A continuous beep indicates that the brake is released. All the machine's functions are blocked.
 - OR
 - Turn the switch 2 to the right (Fig. B) to set the machine to freewheeling. A continuous beep indicates that the brake is released. All the machine's functions are blocked.
- Return the switch 1 or 2 to its initial position (Fig. C) to restore the platform's braking function.

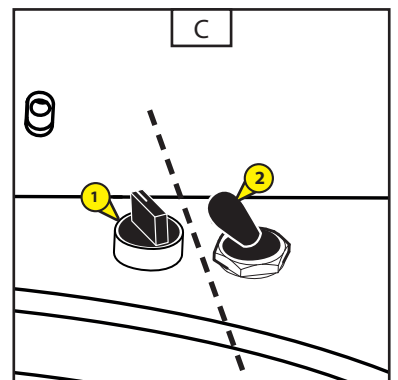
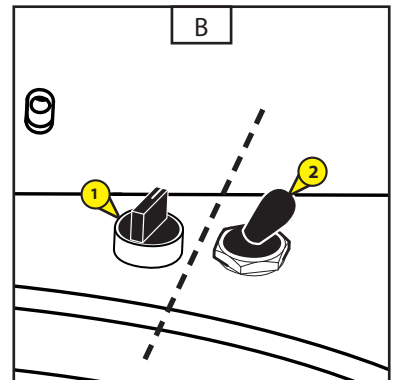
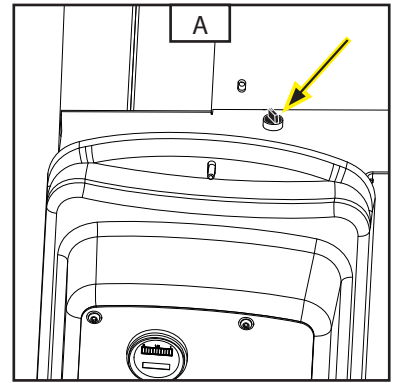

ACTIVATION OF OPTIONS

- Switch on the access platform
- Select position A on the key-operated switch 1 (Fig. A) (controls operated from the basket control console).
- Press the control keys 20, 21 and 22 (Fig. B) simultaneously for 3 seconds:
 - A beep sounds and the three indicator lights A, B and C (Fig. B) flash one at a time.
- Press the control keys (Fig. B - 20 and 21) simultaneously for 3 seconds:
 - The indicator lights A, B and C (Fig. B) are extinguished.
- Select the desired function by briefly pressing the control buttons 20, 21 or 22 (Fig. B):
 - Control key 20: audible beep on all movements (indicator lamp A lit = function enabled).
 - Control key 21: flashing light (indicator lamp B lit = function enabled).
 - Control key 22: maintenance reset (indicator lamp C lit = function enabled).
- After confirming your choice, exit the menu by pressing one of the control keys 20, 21 or 22 (Fig. B) until the three indicator lamps A, B and C flash.
- Validate the operation by pressing the emergency stop button 15 (Fig. B).
- Turn the emergency stop button 15 (Fig. B) a quarter-turn to the right to restore the power supply (the switch will return automatically to its initial position).

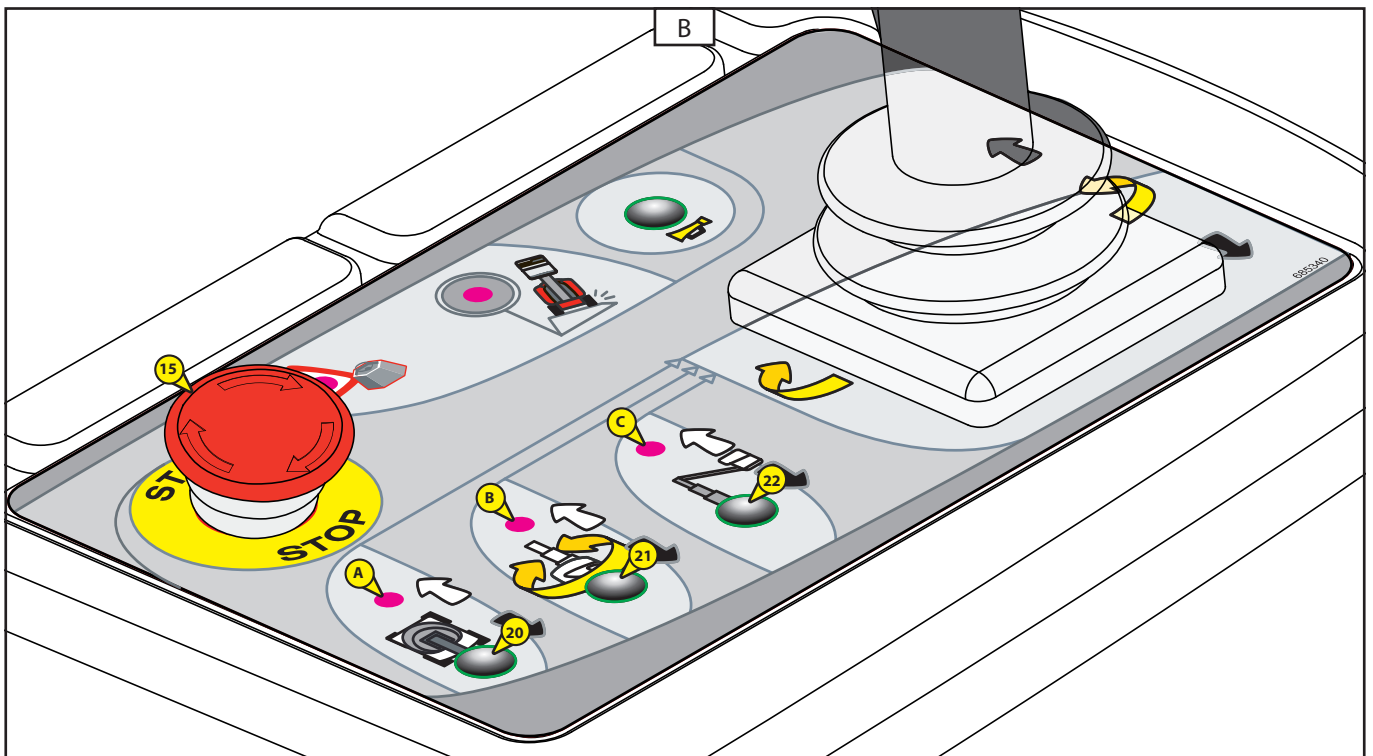
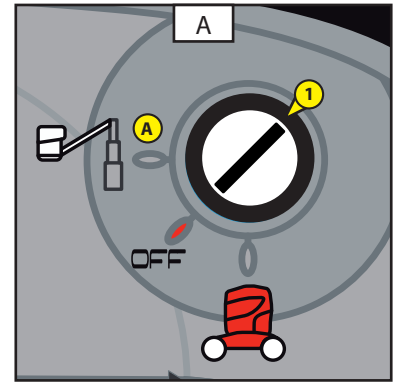

1 - SAFEMANSYSTEM

The "Safe Man System" option is a safety system that cuts off all controls from the basket when activated by the user of the access platform.

OPERATION

- Every time the platform is powered up the system is checked: a beep sounds and the blue light 27 flashes.
- When pressure is applied to the safety edge 26, the system cuts off all platform controls. The blue flashing light 27 flashes and the horn is sounded.
- If the user stops applying pressure to the safety edge:
 - Pressing once on the platform's 'OFF' reset button 25 allows the user to retake control of the platform controls. The flashing blue light 27 and horn are deactivated.
- If the user continues to apply pressure to the safety edge:
 - By pressing the platform's "OFF" reset button 25 once, the user can resume control of the platform. The flashing blue light 27 and the horn will stop when the user ceases to apply pressure to the safety edge.

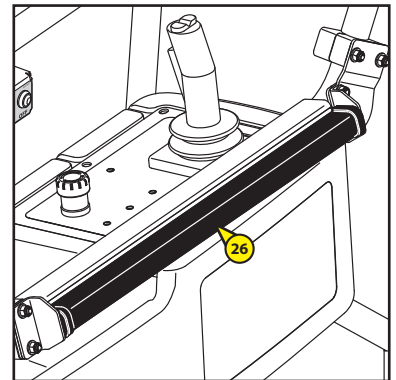
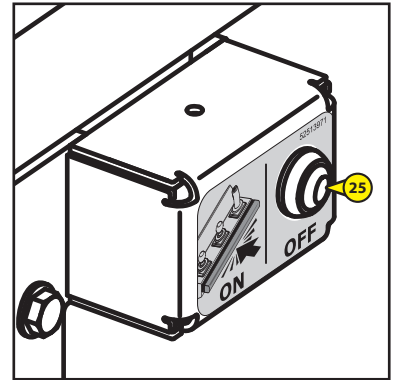

3 - MAINTENANCE

TABLES OF CONTENTS

ORIGINAL MANITOU SPARE PARTS AND EQUIPMENT	3-4
START-UP CHECKLIST	3-5
FILTER ELEMENTS	3-6
LUBRICANTS	3-6
SAFETY COMPONENTS	3-6
SERVICING SCHEDULE - VJR EVOLUTION	3-7
DAILY OR EVERY 5 HOURS' SERVICE	3-8
EVERY 50 HOURS OF SERVICE	3-13
EVERY 100 HOURS OF SERVICE	3-15
EVERY 200 HOURS OF SERVICE	3-18
OCCASIONAL MAINTENANCE	3-18

ORIGINAL MANITOU SPARE PARTS AND EQUIPMENT

OUR PERSONNEL LIFTING PLATFORMS MUST BE SERVICED USING ORIGINAL MANITOU PARTS.

IF YOU USE PARTS THAT ARE NOT ORIGINAL MANITOU PARTS,

YOU RISK

- Legally, incurring liability on yourself in the event of an accident.
- Technically, to cause operating malfunction or reduce the access platform's service life.

THE USE OF COUNTERFEIT PARTS OR COMPONENTS NOT APPROVED BY THE MANUFACTURER,
WILL CAUSE YOU TO LOSE THE BENEFIT OF THE CONTRACTUAL GUARANTEE.

BY USING ORIGINAL MANITOU PARTS FOR MAINTENANCE OPERATIONS,

YOU BENEFIT FROM OUR KNOW-HOW

Through its network, MANITOU provides the user with:

- Know-how and competence.
- The guarantee of high-quality work.
- Original replacement parts.
- Help with preventive maintenance.
- Efficient diagnostic help.
- Improvements due to experience feedback.
- Training of the operating personnel.
- Only the MANITOU network knows the personnel lifting platform's design in detail and therefore has the best technical capabilities for providing maintenance.

ORIGINAL REPLACEMENT PARTS ARE DISTRIBUTED EXCLUSIVELY BY MANITOU AND ITS DEALER NETWORK.
The dealer network list is available on the MANITOU web site: www.manitou.com

START-UP CHECKLIST

0 = OK 1 = Missing 2 = Incorrect

100	ENGINE	
01	Air filter	
02	Fuel tank	
03	Fuel lines - Filter	
04	Injection or carburetion system	
05	Radiator and cooling system	
06	Belts	
07	Hoses	
101	TRANSMISSION	
01	Direction reversal system	
02	Gear shift	
03	Cut-off pedal	
04	Clutch	
102	AXLES/TRANSFER GEAR BOX	
01	Operation and seal	
02	Stop settings	
103	HYDRAULIC/HYDROSTATIC CIRCUIT	
01	Tank	
02	Pumps and couplings	
03	Tightening of connections	
04	Lift cylinder(s)	
05	Tilt cylinder(s)	
06	Attachment cylinder(s)	
07	Telescope cylinder(s)	
08	Compensation cylinder(s)	
09	Steering cylinder(s)	
10	Distributor	
11	Counterbalance valve	
104	BRAKE SYSTEM	
01	Service brake and parking brake operation	
02	Brake fluid level	
105	LUBRICATION AND GREASING	
106	JIB / MANISCOPIC / MANIACCESS ASSEMBLY	
01	Beam and telescope(s)	
02	Skid	
03	Articulated joints	
04	Fork carriage	
05	Forks	
107	MAST ASSEMBLY	
01	Fixed and mobile uprights	
02	Fork carriage	
03	Chains	
04	Rollers	
05	Forks	

108	ACCESSORIES	
01	Fitting on machine	
02	Hydraulic couplings	
109	CABIN / PROTECTOR/ELECTRIC CIRCUIT	
01	Seat	
02	Dashboard and radio	
03	Sound and visual alarm /safety system	
04	Heating / Air conditioning	
05	Windscreen wiper / windscreen washer	
06	Road horn	
07	Reversing sound alarm	
08	Road lights	
09	Additional lights	
10	Revolving light	
11	Battery	
110	WHEEL	
01	Rims	
02	Tire / Pressure	
111	SCREWS	
112	FRAME AND BODYWORK	
113	PAINTWORK	
114	GENERAL OPERATION	
115	OPERATOR'S MANUAL	
116	CUSTOMER INSTRUCTIONS	

FILTER ELEMENTS

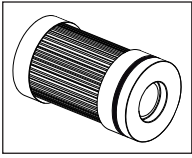

HYDRAULIC OIL CARTRIDGE
Part number: 746308
Change: 100 H

LUBRICANTS

PARTS TO BE LUBRICATED	CAPACITY	RECOMMENDATION	PACKAGING	REFERENCE
HYDRAULIC OIL TANK	22 Liters	MANITOU ISO 46 HYDRAULIC OIL	20 liters 55 liters 209 liters	582297 546108 546109
GENERAL GREASING TURRET CROWN GEAR & BEARING RACEWAY LUBRICATION		MANITOU High- Performance grease	Cartridge 400 grams	479330
TURRET CROWN GEAR TEETH LUBRICATION		SHELL MALLEUS GL 205 OIL	Aerosol	545834

SAFETY COMPONENTS

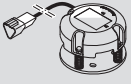
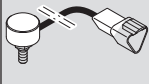
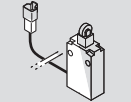
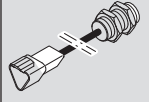
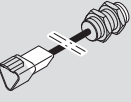
ELECTRIC	
 <p>TILT SENSOR Part number: 52530122</p>	 <p>STEERING POTENTIOMETER Part number: 684731</p>
 <p>OVERLOAD SENSOR Part number: 685823</p>	 <p>JIB DETECTOR Part number: 685820</p>
 <p>TELESCOPE DETECTOR Part number: 685811</p>	

SERVICING SCHEDULE - VJR EVOLUTION



(1): MANDATORY 500 HOUR OR 6 MONTH SERVICE

This service must be carried out after approximately the first 500 hours of operation or within the 6 months following the start-up of the machine (whichever occurs first).

**A = ADJUST, C = CHECK, G = GREASE, N = CLEAN,
P = BLEED, R = REPLACE, V = DRAIN**

	PAGE	 (1)	DAILY OR EVERY 5 HOURS	6 MONTHS OR 50 HOURS	1 YEAR or 100 HOURS	2 YEARS OR 200 HOURS	OCCASIONAL
TIRES							
WHEEL NUT TIGHTENING	3-14	C		C	◀◀	◀◀	
CONDITION OF WHEELS AND TIRES	3-8	C*			C*	◀◀	
HYDRAULIC							
HYDRAULIC OIL LEVEL	3-10	C	C	◀◀	◀◀	◀◀	
HYDRAULIC OIL	3-16	V/R			V/R	◀◀	
HYDRAULIC CIRCUIT STRAINER	3-16	N			N	◀◀	R
HYDRAULIC FILTER	3-16				R	◀◀	
BACKUP PUMP	3-13	C		C	◀◀	◀◀	
ELECTRICITY							
BATTERY CHARGE	3-9	C	C	◀◀	◀◀	◀◀	
BATTERIES	3-9	C	C	◀◀	◀◀	◀◀	
BATTERY ELECTROLYTE SPECIFIC GRAVITY	3-10	C	C	◀◀	◀◀	◀◀	
BATTERY ELECTROLYTE LEVEL	3-10	C	C	◀◀	◀◀	◀◀	
TIGHTNESS OF THE ELECTRICAL POWER CABLES	-	C		C	◀◀	◀◀	
BATTERY REPLACEMENT	3-19						R
BATTERY TRAYS	3-11	V	V	◀◀	◀◀	◀◀	
CLEANING THE ELECTRIC MOTOR BRUSHES WITH COMPRESSED AIR	3-14			N	◀◀	◀◀	
CONDITION OF THE MANIPULATOR BELLOWS	3-11	C	C	◀◀	◀◀	◀◀	
FRAME							
TURRET ORIENTATION CROWN GEAR	3-15	G			G	◀◀	
TIGHTNESS OF THE SCREWS IN THE TURRET ORIENTATION CROWN GEAR	3-15	C			C	◀◀	
LIFTING STRUCTURE							
MAST	3-13	G		G	◀◀	◀◀	
SHIMMING OF TELESCOPE PADS	-	C/A		C/A	◀◀	◀◀	C/A
TELESCOPE PAD WEAR	3-19	C/R		C/R			C/R
TIGHTNESS OF THE BOLTS ON THE TURRET ROTATION ENGINE	3-17	C			C	◀◀	
SAFETY COMPONENTS							
JIB POSITION SENSORS	3-11	C	C	◀◀	◀◀	◀◀	
TELESCOPE POSITION SENSOR	3-11	C	C	◀◀	◀◀	◀◀	
TILT SENSOR	3-12	C	C	◀◀	◀◀	◀◀	
OVERLOAD SENSOR	3-17	C*			C*	◀◀	
MACHINE STICKER	3-12	C	C	◀◀	◀◀	◀◀	
PLATFORM							
GENERAL INSPECTION	3-8	C	C	◀◀	◀◀	◀◀	
FUNCTIONAL INSPECTION	3-8	C	C	◀◀	◀◀	◀◀	
OVERLOAD	3-18					C	
STOPPING DISTANCE	3-18					C	
SLINGS	3-20						
OPTION							
STATUS OF SAFE MAN SYSTEM	3-12		C				

*: Consult your dealer

DAILY OR EVERY 5 HOURS' SERVICE

1 - GENERAL INSPECTION

CHECK

- Meticulously inspect the machine and check that there is no weld cracking, corrosion or structural damage, loose or missing screws, hydraulic leaks, damaged control cable or loose electrical connections, and check the condition of the tires (no tears, wear).

2 - FUNCTIONAL INSPECTION

CHECK



Any platform malfunction must be detected before the platform is started up each day. Identify and remove the platform from service if a malfunction is detected.

Find a test area on a firm and even surface that is free of any obstacle.

When maneuvering the platform (lifting, rotation, etc.), look around and above you. Pay particular attention to electrical cables and any object that may be within the access platform's field of operation.

EMERGENCY STOP

- Hold down the ground control emergency stop buttons.
 - > Result: the platform must stop and there should not be any active function.
- Pull the red emergency stop button to the operational position.
- Carry out the test with the basket emergency stop button. Only controls from the ground are permitted.

DEAD MAN FUNCTIONS

- Without holding down the lifting validation button known as dead man, select a platform raising function.
 - > Result: the platform must not rise.
- Hold down the lifting validation button known as dead man and select a platform raising function.
 - > Result: the platform should rise.
- Perform this test on the lifting, lowering turret rotation and side shift functions of the base and basket consoles in order to obtain the same result.

HORN

- Press the basket horn button.
 - > Result: the horn should sound.

RAISING / LOWERING FUNCTIONS

- From the base console, select all the lifting and then lowering functions.
 - > Result: the platform should rise and then lower.
- From the basket console, select all the lifting and then lowering functions.
 - > Result: the platform should rise and then lower.

TURRET ROTATION FUNCTION

- From the basket console, select the left then right turret rotation function.
 - > Result: the turret should rotate left then right.
- Carry out same test from the base console.

STEERING

NOTE: When testing the steering and translation functions, position yourself in the platform so you turn in the direction of movement of the machine.

- From the basket console, select the steering control.
 - > Result: the steering wheels must turn in the direction controlled.

TRAVELING AND BRAKING

- Select a travel control.
 - > Result: the machine must move in the direction indicated by the white arrow to move forward and the black arrow to reverse and then stop when the control is released.

TRAVEL SPEED IN WORKING MODE

- Lift one or more platform arms and / or extend the telescope.
- Perform a translation movement.
 - > Required result: the side shift must be carried out at operating speed.

TILT SENSOR

NOTE: Fold the arms for this operation.

- Place the platform in a tilt position that is more than that authorized.
 - > Result to be obtained: the movements of extending the telescope and raising the jib must be blocked. The tilt indicator light is lit on the base console and the basket console and the vibrating buzzer also sounds intermittently in the basket.

OVERLOAD SENSOR

NOTE: Fold the arms into transport position for this operation.

- Place a heavier weight than that indicated in the basket.
 - > Result: the movements of extending the telescope, raising the arm, and turret rotation must be blocked. The overload indicator light is lit in the basket and the base console, and the vibrating buzzer is also permanently activated in the basket.

3 - BATTERY CHARGE

CHECK

The access platform's autonomy is 5 hours of operation with the battery fully charged.

- When all the bars are blackened, this means that the battery is fully charged.
- When using the access platform, the number of bars indicates the level of charge in the battery.
- When there are only two bars still blackened, this means that the battery is 80% discharged and requires to be recharged.

NOTE: The battery charge level must not drop below the 20% charge level, otherwise there is the risk of rapid and irreversible damage to the batteries.

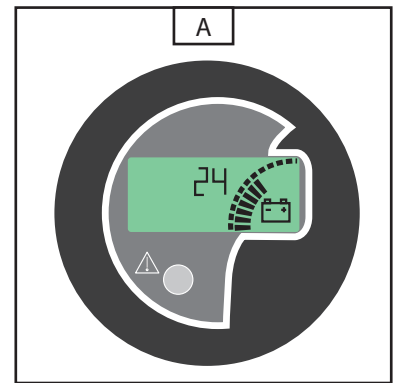

4 - BATTERY

CHARGE

The platform has an electric charger located on the turret under the ground control and emergency station.

How to use the charger:



Recharge batteries in a well-ventilated space, in which smoking is strictly forbidden, to avoid any risk of explosion.

- Open the turret covers 1 (Fig. B) and leave them open throughout the charging process.
- Switch off the power supply to the access platform using the battery cut-off 2 (Fig. C).
- Do not place any metal object on the battery (risk of a short-circuit).
- Do not remove the cell caps.
- Do not recharge the battery if the electrolyte's temperature is over 40°C. Allow it to cool down first.
- Plug the charger into the mains socket.
- Never interrupt a battery recharging cycle once started. Never place the batteries on charge for a period of just a few hours, as this will quickly damage your battery.

NOTE: Around 10 hours of charging are required for batteries discharged 70% to 80%.

Once the battery is charged:

- Disconnect the charger plug.
- Restore the power to the access platform via the battery cut-off 2 (Fig. C).
- Close the turret covers 1 (Fig. B).

NOTE: The charger has been factory set with its own cable. If this cable requires replacement, ensure that you fit a cable of the same section and the same length.

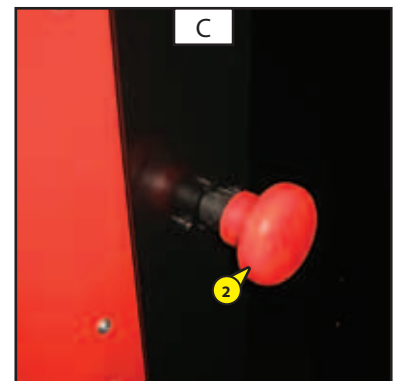
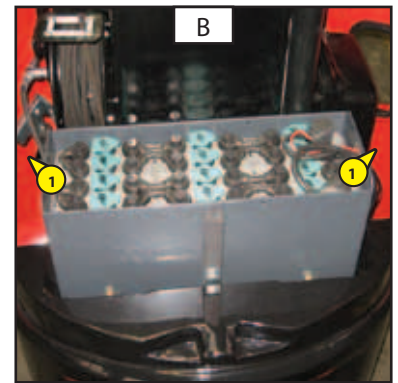

5 - HYDRAULIC OIL LEVEL

CHECK

- Place the platform in the transport position.
- Open the left-hand cowl.
- The oil level must be in the middle of the indicator 1 (Fig. A).
- If necessary, add oil (see "LUBRICANTS") through the filling port 2 (Fig. B).

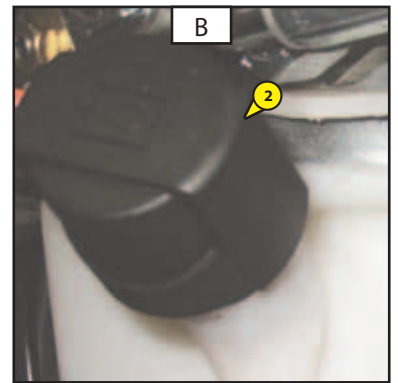
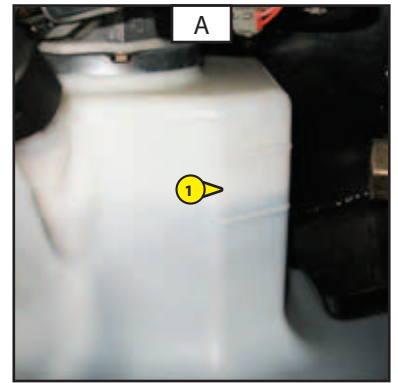

6 - BATTERY ELECTROLYTE SPECIFIC GRAVITY

CHECK

The electrolyte's specific gravity varies with temperature but a minimum value of 1270 at 16°C must be maintained.

In the hatched part (Fig. C), the battery is normally charged. Above this hatched area, the battery must be recharged. The density must not vary by 0.0025 units from one element to another of the battery.

- Recharge the battery and wait for 1 hour before checking the electrolyte specific gravity in each battery cell using a hydrometer.
- Never check after having added distilled water.

Handling and servicing a battery can be dangerous, take the following precautions:

- Wear protective goggles.
- Keep the battery horizontal.
- Never smoke or work near a naked flame.
- Work in a well-ventilated area.
- In the event of electrolyte being spilled onto the skin or splashed in the eyes, rinse thoroughly with cold water for 15 minutes and call a doctor.

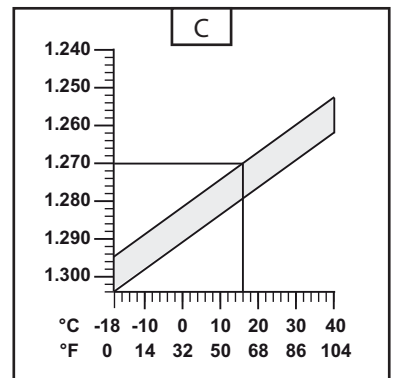

7 - BATTERY ELECTROLYTE LEVEL

CHECK

Check the electrolyte level in each cell of the battery.

- Open the turret covers.
- Remove the cap 1 (Fig. D) from each battery cell.
- The level must be 1 cm above the plates in each cell.
- If necessary, top up with clean distilled water, kept in a glass container.
- Clean and dry the caps 1 (Fig. D), and refit them.
- Check the terminal connections and lightly smear with petroleum jelly to prevent the formation of verdigris.

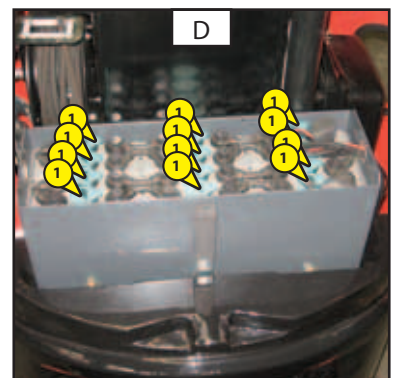

8 - BATTERY TRAY

DRAIN

- Switch off the access platform
- Open the turret covers.
- Check for water on the battery.
- Drain away any water present on the battery with a suction bulb (Fig. A).



The presence of water in the tray causes damage to the battery, causing it to short-circuit at the plus or minus terminals.
Dispose of the dirty water (electrolyte+water) in an ecological manner.

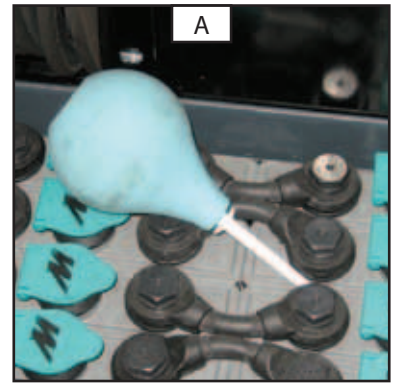

9 - CONDITION OF MANIPULATOR RUBBER BELLOWS

CHECK

- Switch off the access platform.
- Climb into the basket for this operation.
- Check the condition of the manipulator's rubber bellows 1 (Fig. B) by operating it to perform a movement.

The bellows must not show any crazing or cracks, which risk to allow water infiltration and adversely affect the correct operation of the machine.

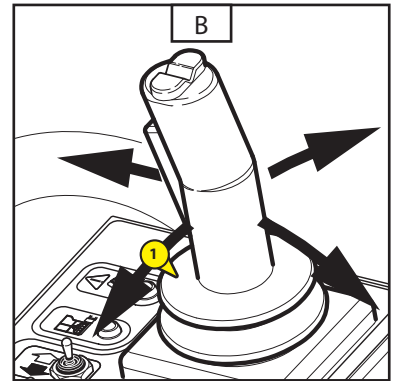

10 - JIB DOWN POSITION SENSOR

CHECK

Lower the jib to transport position for this operation.

- Conduct a translation at transport speed.
- Raise the jib.
- Move forwards.
- The access platform must switch to working mode.



Forbid the use of the access platform in the event of a malfunction.
Contact your dealer.

11 - TELESCOPE DOWN POSITION SENSOR

CHECK

Lower the telescope to transport position for this operation.

- Conduct a translation at transport speed.
- Raise the telescope.
- Move forwards.
- The access platform must switch to working mode.



Forbid the use of the access platform in the event of a malfunction.
Contact your dealer.

12 - TILT SENSOR

CHECK

Test on sensor 1 (Fig. A) (see "2 - DESCRIPTION: INSTRUMENTS AND CONTROLS")



Forbid the use of the access platform in the event of a malfunction.
Contact your dealer.

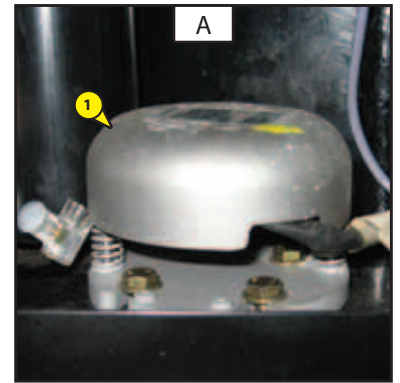

13 - MACHINE STICKERS

CHECK

- Consult your dealer.

14 - CONDITION OF SAFEMANSYSTEM (OPTION)

CHECK

Press the safety edge 1 (Fig. B) and check:

- That all the platform's movements stop.
- The operation of the flashing blue light and horn.
- The operation of the platform's movements when you press the "OFF" button 2 (Fig. C) once.
- If the safety edge is faulty, the blue flashing light will flash quickly and a special beep will be activated. The machine can continue to operate normally however.
- If the "OFF" reset button is not operating correctly, use the emergency stop to reset the platform.

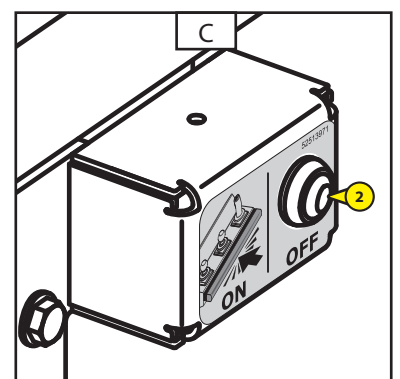
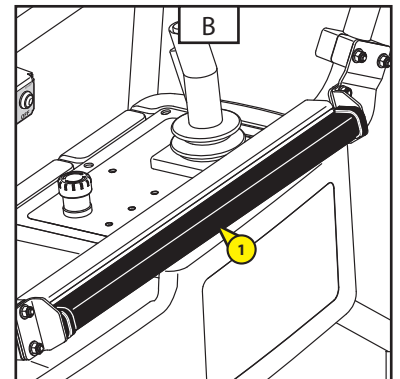

EVERY 50 HOURS OF SERVICE

1 - GREASE THE MAST

GREASE

- Degrease the whole of the mast on all 4 sides with a solvent (Fig. A).
- Apply lubricant (Fig. B) (see "LUBRICANTS").

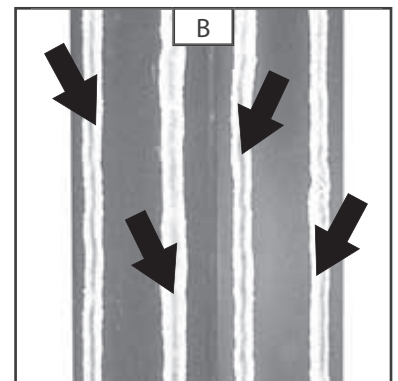
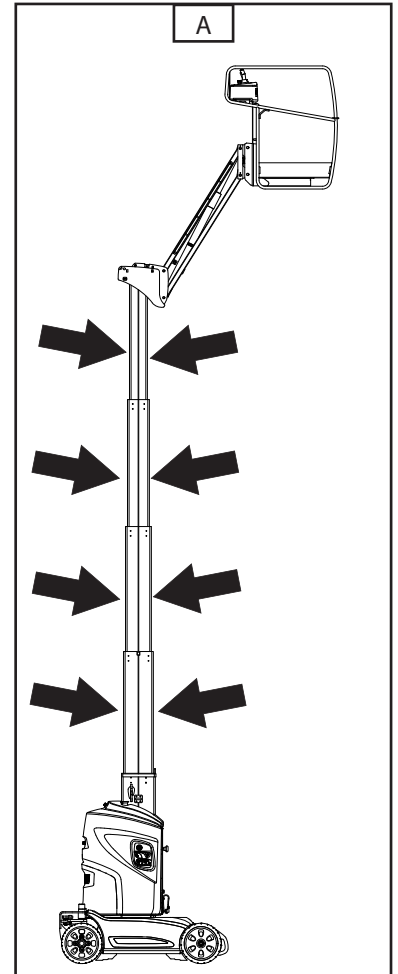

2 - BACKUP PUMP

CHECK

- Switch off the access platform.
- Check that the emergency pump is working correctly (see "2 - DESCRIPTION: RESCUE PROCEDURE")
- Perform a movement (e.g.: lower telescope mast).



You must never use the lifting platform under any circumstances if the pump is not working.

3 - WHEEL NUT TIGHTENING

CHECK

Check the wheel nut tightening torques:

- The tightening torque for the front wheels 1 (Fig. C) is: 11,5 daN.m \pm 4%.
- The tightening torque for the rear wheels 2 (Fig. D) is: 17,8 daN.m \pm 5%.



Failure to observe this instruction may cause the wheel studs to be damaged or broken, and the wheels to be deformed.

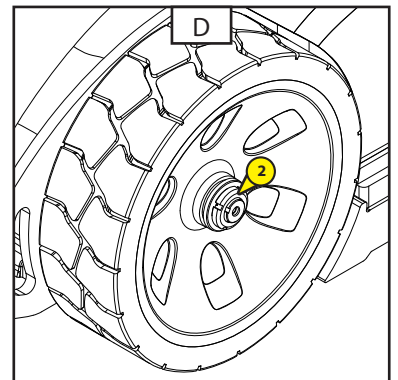
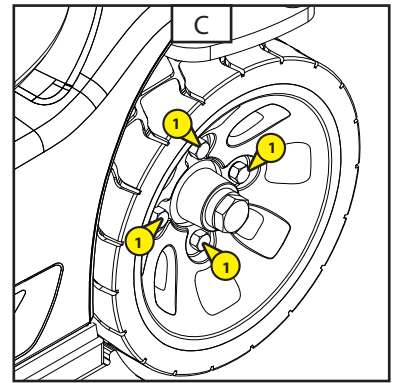

4 - CLEANING THE ELECTRIC MOTOR BRUSHES WITH COMPRESSED AIR

CLEAN

- Remove the two screws and the metal collar (Fig. A).
- Remove the screw and clean the brushes of the mini-unit (Fig. B).

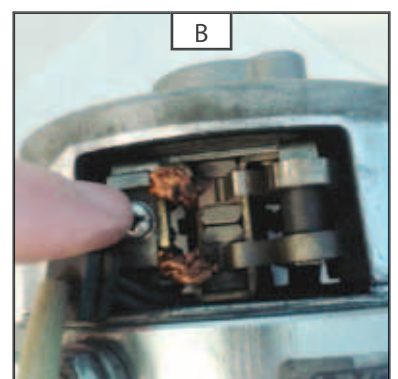
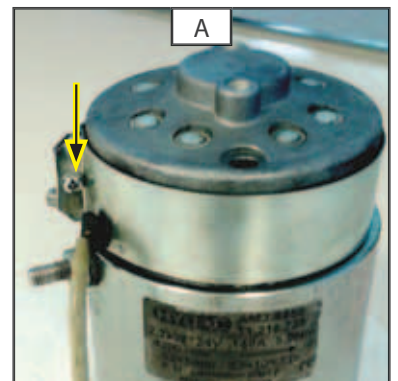

EVERY 100 HOURS OF SERVICE

1 - TURRET ORIENTATION CROWN GEAR

GREASE

The bearing raceways must be greased and the teeth lubricated every 100 operating hours, as well as before and after a long period at a standstill.

- Remove the turret covers 1 (Fig. A).
- Remove the right chassis cover 2 (Fig. B).
- Use a brush to apply lubricant (see "LUBRICANTS") to the crown and pinion teeth 3 (Fig. C).

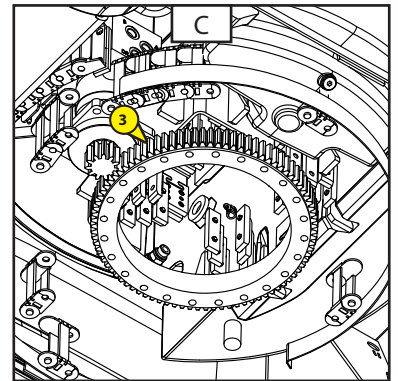
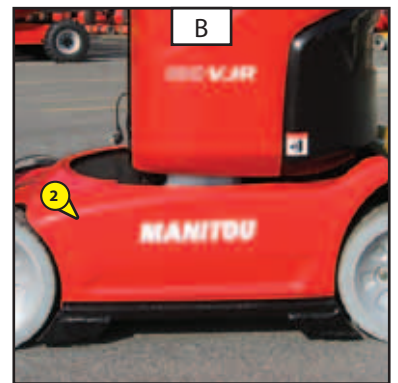
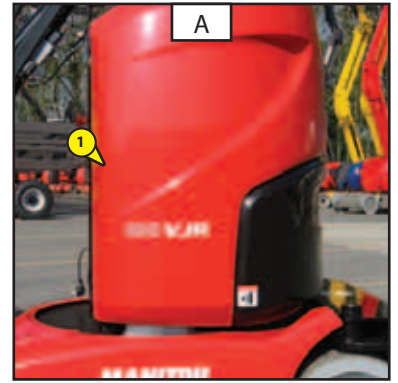

2 - TIGHTNESS OF THE BOLTS IN THE TURRET ORIENTATION CROWN GEAR

CHECK

The tightness of the bolts 4 (Fig. D) should be checked at the latest after 50 hours of service. Then the check should be repeated every 100 hours of service.

- The tightening torque for the bolts is 12 daN.m \pm 10%.

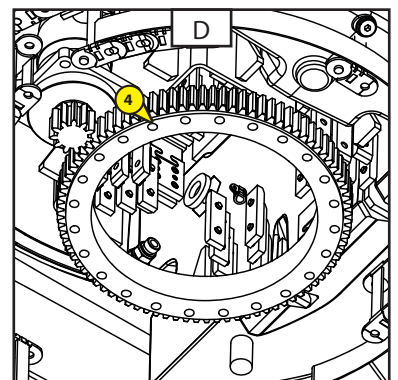

3 - HYDRAULIC OIL

DRAIN - REPLACE

- Set the access platform on a horizontal surface in transport position.
- Open the right-hand cover.

DRAINING THE OIL:

- Place a receptacle under the drain plug 1 (Fig. A) and unscrew the plug.
- Remove the filling cap to assist draining.

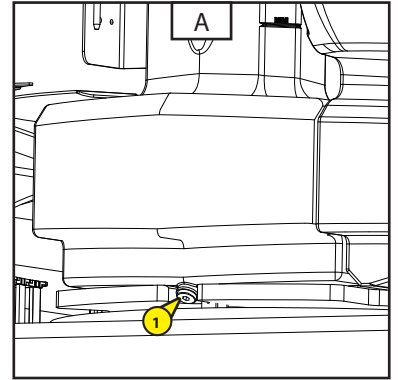

4 - HYDRAULIC CIRCUIT STRAINER

CLEAN

- Set the access platform on a horizontal surface in transport position.
- Open the right-hand cover.

DRAINING THE OIL:

- Place a receptacle under the drain plug 1 (Fig. A) and unscrew the plug.
- Remove the filling cap to assist draining.

CLEANING THE STRAINER:

- Remove the mini hydraulic unit 2 (Fig. B), and remove the strainer which is at the end of the plastic tube 3 (Fig. C).

FILLING UP THE OIL:

- Re-fit and tighten the drain plug 1 (Fig. A)
- Fill with hydraulic oil (see "LUBRICANTS") via the filler port (see: "HYDRAULIC OIL LEVEL").
- The oil level must lie between MIN and MAX on the gage.

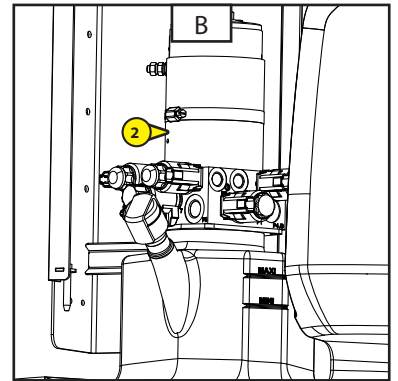

Dispose of the drain oil in an ecological manner.

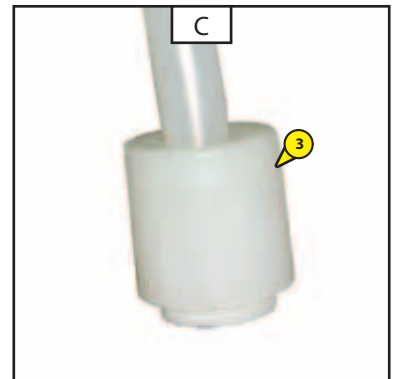

5 - HYDRAULIC FILTER

REPLACE

- Set the access platform on a horizontal surface in transport position.
- Open the right-hand cover.
- Unscrew the screw 4 (Fig. D) and take out the filter located inside.
- Filter to be used: see "FILTER ELEMENTS".

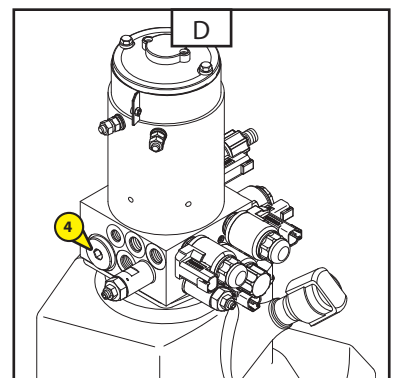

6 - TIGHTNESS OF THE BOLTS ON THE TURRET ROTATION ENGINE

CHECK

- Place the machine on level ground
- Remove the left and right covers of the turret.
- Remove the left and right covers from the chassis.
- Remove the engine bonnet and the turret lower guard.
- Check the tightness of the 4 bolts 1 (Fig. A)
- The tightening torque for the bolts is 13.5 daN.m \pm 10%.

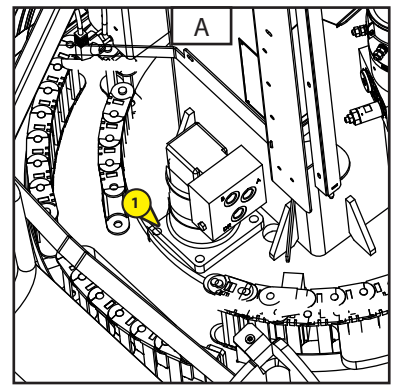

7 - OVERLOAD SENSORS

CHECK

- Fold the jib into transport position for this operation.
- Place a heavier weight than indicated in the basket (see chapter "2 DESCRIPTION: SPECIFICATIONS").
- All the movements of the machine are blocked (the overload indicator light is lit in the basket and the vibrating buzzer is also permanently activated in the basket).



Forbid the use of the access platform in the event of a malfunction.
Contact your dealer.

EVERY 200 HOURS OF SERVICE

1 - OVERLOAD

CHECK

- The overload must be activated between 1.1 and 1.2 times the rated load (see chapter "2 - DESCRIPTION: SPECIFICATIONS").
- Rated load 200 kg.
 - > Result to be obtained: the overload must be active between 220 kg and 240 kg, the overload sensors must be activated at the same time.

NOTE: Refer to the repairs manual for the overload setting.

2 - STOPPING DISTANCE

CHECK

Stopping distance on horizontal ground:

- The stopping distance is checked on even ground with 1.1 times the rated load in the basket.
- Reach the maximum speed and then release the manipulator.
 - > Required result:

On horizontal ground	Stopping distance
Transport speed	700 mm + or - 200 mm
Working speed	70 mm + or - 30 mm

Checking the brakes on a slope:

- Put the access platform on a 20% slope gradient, static with 1.1 times the load in the basket.
 - > Required result: the platform must not reverse within one minute.

OCCASIONAL MAINTENANCE

1 - BATTERY

REPLACE

When it is necessary to replace the battery, it is essential to use batteries of the same weight and capacity in order to ensure the machine's stability.



A traction battery is heavy (215 kg); a lifting system should therefore be used.

PRECAUTION:

- Keep the battery quite straight while lifting it.
- Ensure that you keep the slings apart to avoid a short-circuit.
- Ensure that the battery is correctly positioned on the access platform.

If you are installing new batteries, recharge them 3-5 times after 3 to 4 hours of use.

2 - CHECKING FOR WEAR OR INCORRECT SHIMMING OF TELESCOPE PADS

CHECK



This stability test is to be conducted by qualified personnel who will implement the necessary protective measures for making this operation safe (securely anchoring the machine to the ground).

TEST CONDITIONS:

- Platform on level ground.
- Telescope fully extended.
- Jib raised to horizontal.
- Carry out the test in a location that is sheltered from the wind.

TEST:

- Fix a load of 200 kg onto the basket, taking care to position the load's center of gravity in the center of the basket.
- Attach a plumb line to the overload shaft (see Fig. A).

RESULT:

- The distance between the plumb line and the turret reinforcement must not exceed 1700 mm (Fig. B).

CHECKING INTERVALS:

The check must be made every time that one of the lifting platform's major components is modified, namely:

- Alteration or change to the telescope.
- Alteration or change to the counterweight.
- Alteration or change to the frame.
- Alteration or change to the turret.
- Alteration or change to the jib.
- Alteration or change to the wheels.
- Alteration or change to the pads or telescope shims.
- Alteration or change to the basket.
- At each periodic general inspection of the machine, in accordance with the prevailing legislation.

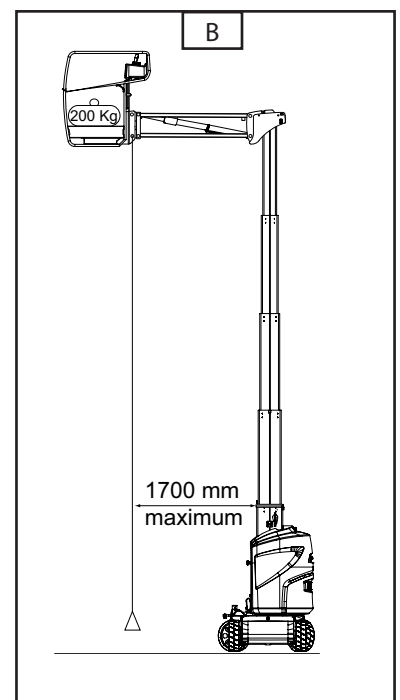
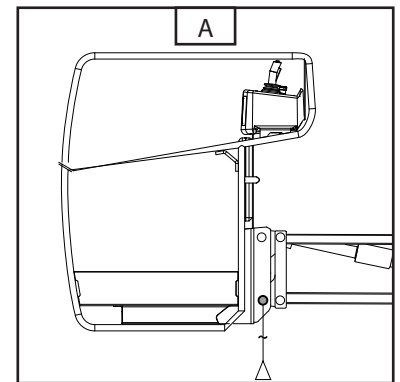



The platform must be lifted using the two anchor points.

- Take into account the position of the access platform centre of gravity for lifting.
- Place the hooks in the slinging points provided for this purpose, see "1 - SAFETY STICKERS: SLINGING POINT".

