

HD 25

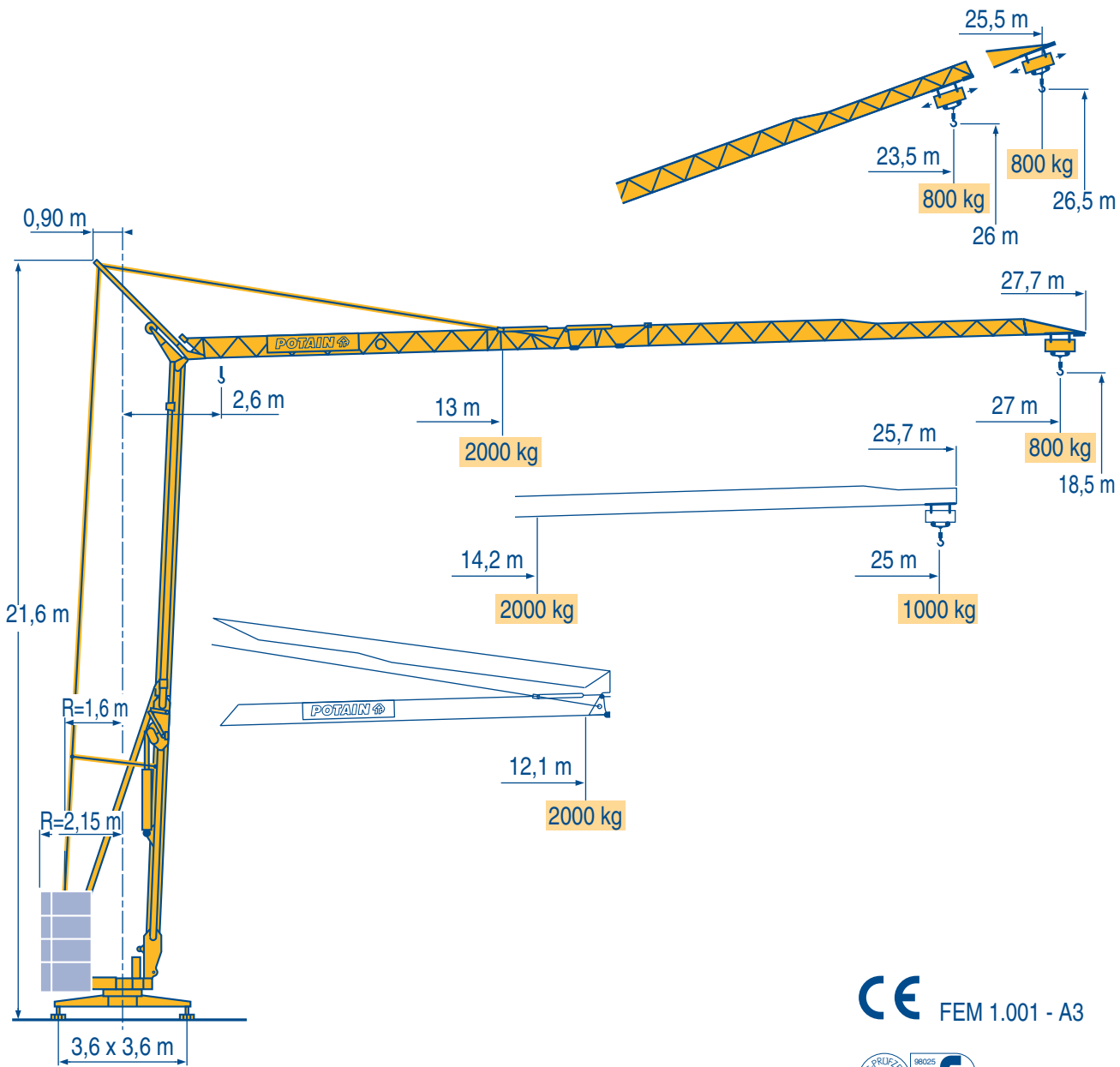

LOW 2

Igo
HD
HDM



HDT



GTMR



CITY CRANE



TOPKIT MD
MAXI MD



MAXI TOPKIT



Topless MDT



MR



CE FEM 1.001 - A3



POTAIN 

Courbes de charges
Lastkurven



Load diagrams
Curvas de cargas



Curve di carico
Curva de cargas

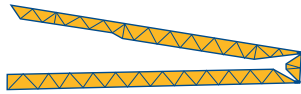

27 m 2,6 ▶ 12,1
2000 2000



25 m 2,6 ▶ 12,1
2000 2000

13 14 15 16 17 18 19 20 21 22 23 24 25 26 27 m
2000 1820 1670 1540 1430 1330 1245 1165 1100 1035 980 930 880 840 800 kg

14,2 15 16 17 18 19 20 21 22 23 24 25 m
2000 1875 1730 1610 1500 1405 1315 1240 1170 1110 1050 1000 kg

LOW 1

Flèche relevée
Ausleger in Steilstellung



Luffing jib
Flecha izada



Braccio impennato
Lança inclinada

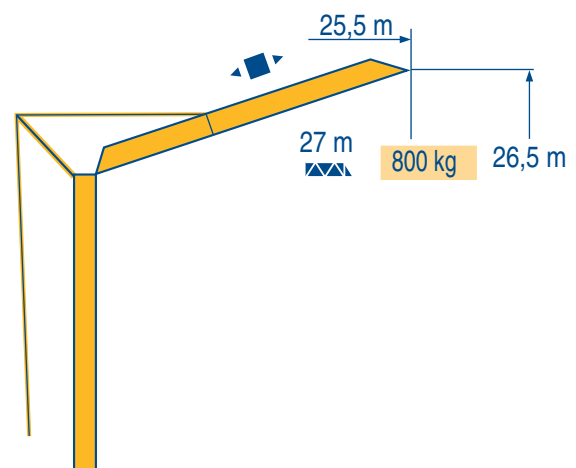
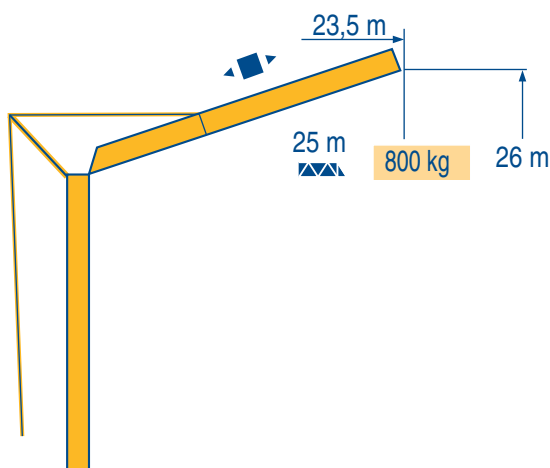

LOW 1



Chariot distributeur



Verfahrbare laufkatze



Traversing trolley



Carro distribuidor



Carrellino distributore



Carro distribuidor



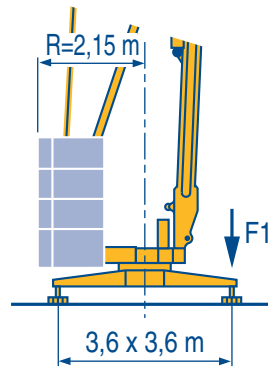

F1 ● 15,4 t ■ 7,4 t

▲ 8,2 t

LOW 1

| | | | | | | | | | | | | |
|---|---|---|---|---|--|----|---|---|--|---|---|---|
| ● | Réactions en service | F | Reaktionskräfte in Betrieb | D | Reactions in service | GB | Reacciones en servicio | E | Reazioni in servizio | I | Reações em serviço | P |
| ■ | Réactions hors service | | Reaktionskräfte außer Betrieb | | Reactions out of service | | Reacciones fuera de servicio | | Reazioni fuori servizio | | Reações fora de serviço | |
| ▲ | A vide sans lest (ni train de transport) avec flèche et hauteur maximum | | Ohne Last, Ballast (und Transportachse), mit Maximalausleger und Maximalhöhe. | | Without load, ballast (or transport axles), with maximum jib and maximum height. | | Sin carga, sin lastre, (ni tren de transporte), flecha y altura máxima. | | A vuoto, senza zavorra (ne assali di trasporto) con braccio massimo e altezza massima. | | Sem carga (nem trem de transporte)-sem lastro com lança e altura máximas. | |

| | | | | | | | | ch - PS hp | kW |
|-----|----------|---------------------|---------|------|------|------|-----|---------------|----|
| ▲ | 9 PC 10 | m/min | 6,6 | 20 | 40 | 8,2 | 6 | | |
| | | kg | 2000 | 2000 | 1000 | | | | |
| ▼ | 9 LVF 10 | m/min | 4 | 20 | 40 | 10,3 | 7,5 | | |
| | | kg | 2000 | 2000 | 1000 | | | | |
| ◀ ▶ | 2 D2 V4 | m/min | 18 - 36 | | | 2 | 1,5 | | |
| ⦿ | RVF 30 | tr/min U/min rpm | 0 → 0,9 | | | 1,5 | 1,1 | | |

| | | | |
|-----------------------|--------|--------|-----------------|
| CEI 38 | IEC 38 | kVA | |
| 400 V(+6% -10%) 50 Hz | | 12 kVA | 84/534 - 87/405 |

LOW 1

| | | | | | | | | | | | | |
|-----|---|---|--|---|--|----|---|---|--|---|---|---|
| ▲ | Levage | F | Heben | D | Hoisting | GB | Elevación | E | Sollevamento | I | Elevação | P |
| ◀ ▶ | Distribution | | Katzfahren | | Trolleying | | Distribución | | Ditribuzione | | Distribuição | |
| ⦿ | Orientation | | Schwenken | | Stewing | | Orientación | | Rotazione | | Rotação | |
| 🎧 | Conforme aux directives CEE 84/534 et 87/405 sur le niveau acoustique | | Gemäss EWG-Richtlinien 84/534 und 87/405 für den Schall-Leistungspegel | | In compliance with the EEC 84/534 and 87/405 Instructions on noise level | | Conforme con las directivas CEE 84/534 y 87/405 sobre el nivel acustico | | Conforme alle direttive CEE 84/534 e 87/405 sul livello acustico | | Conforme as directivas CEE 84/534 e 87/405 sobre o nível acústico | |

Montage
Montage



Erection
Montaje



Montaggio
Montagem

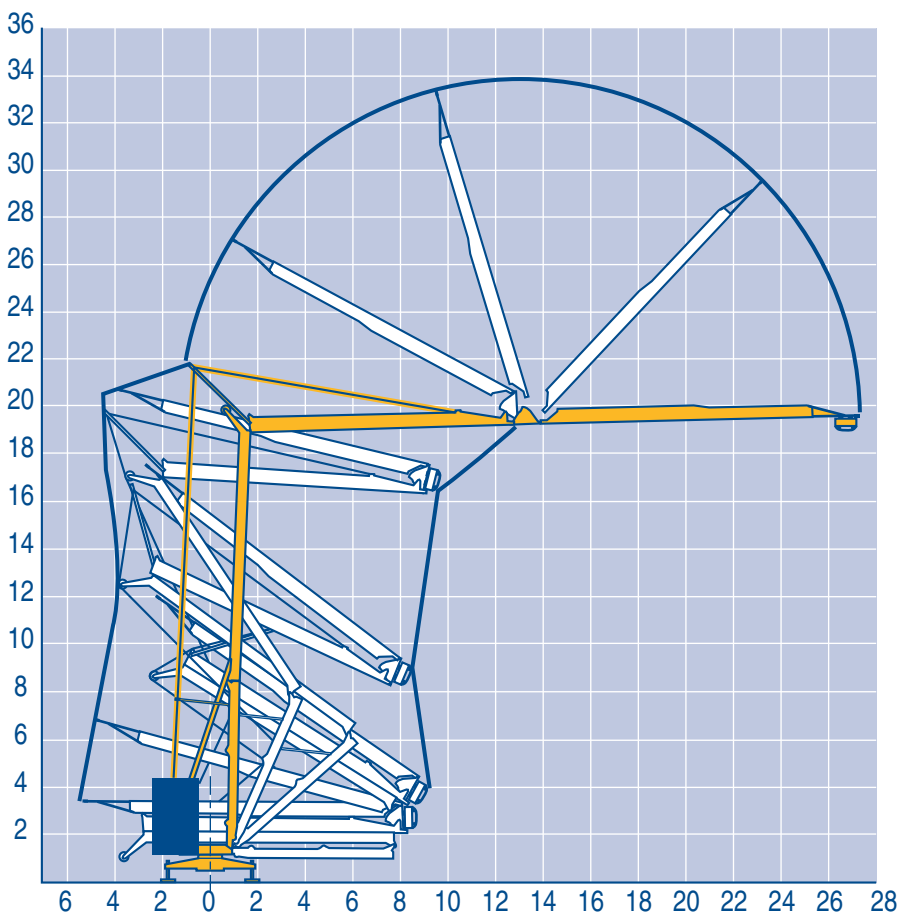

LOW 1

Transport
Transport



Transport
Transporte



Trasporto
Transporte

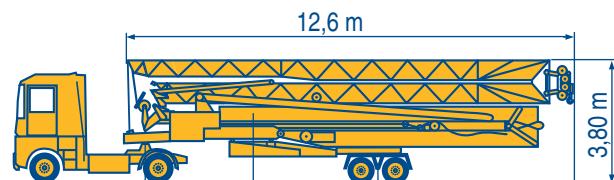

| | | | |
|-------------|--------|--------|--------|
| SL122/J215M | 3,30 m | 3,74 m | 5,12 m |
| SL121/S215M | 3,30 m | 3,74 m | 5,12 m |

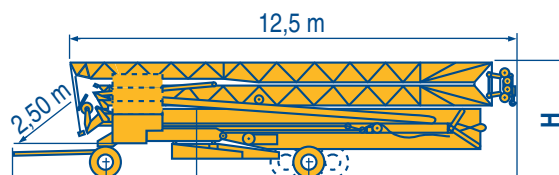

| | | | | | | |
|--------------|--------|--------|--------|--------|---|--------------|
| CJ125M/J215M | 3,36 m | 3,20 m | 3,74 m | 5,12 m | H | 3,85 m |
| DJ126M/S215M | 3,10 m | 3,20 m | 3,74 m | 5,12 m | H | 3,84 m |
| DJ126M/S105 | 3,10 m | 2,32 m | 3,15 m | 5,71 m | H | 3,27 m |
| DS60/S105 | 2,51 m | 2,30 m | 3,15 m | 5,71 m | H | 3,1 m/3,25 m |
| DS60/S80 | 2,51 m | 2,30 m | 3,15 m | 5,71 m | H | 3,1 m/3,25 m |
| DS51/S70 | 1,74 m | 2,30 m | 3,15 m | 5,71 m | H | 3,1 m/3,25 m |

SL122/J215M

SL121/S215M

CJ125M/J215M

DJ126M/S215M

DJ126M/S105

DS60/S105

DS60/S80

DS51/S70

LOW 1



Chantier



Baustelle



Site



Obra



Cantiere



Estaleiro



Document commercial non contractuel. Pour toute information technique se référer à la notice correspondante

Unverbindliches Vertriebsdokument. Für technische Informationen, siehe die entsprechenden Anweisungen.

This commercial document is not legally binding. For any technical information, please refer to the corresponding instructions.

Documento comercial non contractuel. Para cualquier información técnica, ver la noticia correspondiente.

Documento commerciale non vincolante, per tutte le informazioni tecniche fare riferimento al catalogo istruzioni

Documento comercial não contratual. Para qualquer informação técnica complementar consultar as respectivas instruções

POTAIN

18.Rue de Charbonnières, B.P. 173
F-69132 ECULLY Cedex
Tél. (33)04.72.18.20.20
Fax (33)04.72.18.20.00
http://www.potain.com
E-mail : mkt@potain.fr



Manitowoc Crane Group

Deutschland

POTAIN GmbH

Tel : 06.1.05.70.40

Italia

POTAIN S.p.A.

Tel : 0.331.49.33.11

Portugal

POTAIN Portugal

Tel : 22.968.08.89

Singapore

MANITOWOC POTAIN PTE LTD Tel : 227.15.50

Copyright.Reproduction interdite © POTAIN 1998

HD 25

Réf. 1998.02 LOW 7

Reserva de modificaciones / Modifiche riservate / Modificaciones reservadas / Subject to modification / Änderungen vorbehalten / Modificações reservadas

Printed in France

Réalisation HeadLines